

SY-G[®]

Empowering New Frontiers™



OUR COMPANY

We are the catalyst for local technology integrators, helping them to reach for **NEW FRONTIERS** and free themselves from the tyranny of conventional business relationships.

We value and appreciate the effort put forth by each company, no matter the size of the market they serve. We strive to develop win-win, long-lasting, **TRUE PARTNERSHIPS** with all Stakeholders, helping them to diversify and grow their business while achieving financial health and **PEACE OF MIND**.

We foster a "Business Partner-centric culture" that will change the business dynamics between the Vendor and the Business Partner, spearheaded by a **THINK GLOBALLY–ACT LOCALLY** philosophy.



NEW FRONTIERS

Sy-G brings a ground-breaking, enthusiastic and energized attitude into a mature industry. Our products and solutions are envisioned to empower and inspire all Stakeholders to step out of conventional business relationships and transform their businesses. We build our company around a "Business Partner-centric culture" designed to generate competitive advantages across the entire value chain.



TRUE PARTNERSHIP

Sy-G is committed to cultivating win-win relationships with our Stakeholders. We prioritize the development of long-term integral relationships sharing a common purpose and striving for shared goals. We innovate together with our Business Partners by developing products and solutions that help build and grow their businesses while securing them a thriving financial future.



PEACE OF MIND

Sy-G is a world-class vendor providing reliable and cutting-edge products and solutions supporting business continuity. Guaranteeing the highest availability for mission-critical applications is our priority. Our product portfolio complies with international standards and is designed to meet and even exceed the industry's best practices. Our *raison d'être* is to allow customers to concentrate on their business and not have to worry about ours.



THINK GLOBALLY – ACT LOCALLY

Sy-G strives to develop and support the most professional, knowledgeable, and service-focused Business Partner network in order to guarantee customers the reliability of the solutions deployed. We understand that each market is unique with its own individual requirements and technical specifications. We respect and appreciate the local idiosyncrasies because it is our priority to design and supply customized solutions specific to the needs of each territory.



Empowering New Frontiers™



INDEX

CATEGORY



PRODUCTS & SOLUTIONS PORTFOLIO

POWER SOLUTIONS

- ▶▶ UNINTERRUPTIBLE POWER SYSTEMS (UPS)
- ▶▶ BATTERIES

COOLING SOLUTIONS

- ▶▶ PERIMETRAL PRECISION AIR CONDITIONERS
- ▶▶ WALL-FIT PRECISION AIR CONDITIONERS
- ▶▶ INROW PRECISION AIR CONDITIONER
- ▶▶ PACKAGED AIR CONDITIONERS

TECHNICAL FLOORING SOLUTIONS

- ▶▶ RAISED ACCESS FLOOR
- ▶▶ VYNIL TILES

CABINET SOLUTIONS

- ▶▶ • SERVER CABINETS
- ▶▶ • TELECOM CABINETS

INTEGRATED SOLUTIONS

- ▶▶ • COMPACT DATACENTER



POWER SOLUTIONS

Our Power Solutions are reliable and cutting-edge equipment to assure the continuity of mission critical and office applications. Sy-G uses high efficiency technology to guarantee energy savings and environmental care.

SY-G[®]
Empowering New Frontiers™

UNINTERRUPTIBLE POWER SYSTEMS UPS



High-performance UPS units designed to provide continuous, reliable and clean power against downtime and process interruptions to assure continuity of mission-critical, office, medical and military applications.

Our Portfolio includes three different UPS series:

STAND ALONE 1 – 600 KVA

RACK-MOUNT 1 – 20 KVA

MODULAR 20 – 200 KVA / KW



DESCRIPTION OF FEATURES

1. Nomenclature

Model

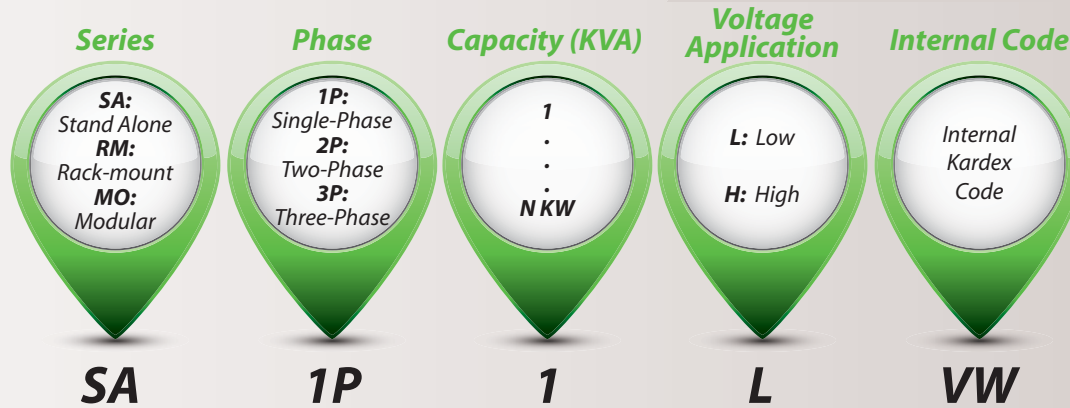

2. True on-line double conversion technology

A true on-line double conversion UPS is a unit where the inverter is always ON. Therefore, it provides clean, high-level quality power to protect mission-critical applications such as servers, sensitive networks, data centers, telecom devices, medical equipment, and industrial processes.

3. DSP Power Factor-Corrected IGBT Rectifier

IGBT-based technology provides $\geq 0,99$ Input Power Factor Correction (IPFC) and an Input Current Total Harmonic Distortion (THDi) of $< 3\%$. This technology avoids disturbances to other loads connected in the same utility power grid, maximizes active power, reduces electricity pay-out, and minimizes wiring and switchboard capacity.

4. DSP-Controlled IGBT Inverter:

DSP-controlled IGBT inverter provides the highest quality output power while ensuring the cleanest output voltage waveform to protect connected loads.

5. Frequency Converter Mode

The UPS can be used as a frequency converter from 50 Hz input to 60 Hz output, or from 60 Hz input to 50 Hz output to suit the requirements of power-sensitive equipment.

6. Emergency Power Off (EPO) function

EPO function is designed to switch off the UPS in emergency conditions (fire, flood, etc.). It will turn off the rectifier, inverter, battery, and bypass, thus shutting off the load immediately. If the input utility is present, the UPS's controls will remain active; however, the output will be turned off. To remove the remaining power from the UPS, the external feeder breaker must be opened.

7. Energy-saving, ECO mode operation

ECO mode is designed to offer 97% efficiency reducing energy usage and cost. The UPS powers the load via its static bypass while returning to on-line double conversion mode on a timely manner when needed.

DESCRIPTION OF FEATURES

8. Multiple communication ports

The UPS units employ a wide range of advanced communication protocols (USB, RS-232, and SNMP), which provide remote management capabilities over the network and enable centralized management.

9. Intelligent battery charger and ABM (Advanced Battery Management) design for optimized performance

The Intelligent battery charger showcases some important features, such as temperature compensation and battery current limits. These features maximize battery performance, extend its lifespan and optimize its recharging time.

Advanced battery management provides real-time information concerning battery capacity and back-up time. The UPS can test the batteries automatically at adjustable periods, or it can be done manually without shutting off the system.

10. Wide-input voltage range for harsh environments

The UPS provides stable power to connected devices even under unstable electrical environments. Please refer to individual product specifications for detailed information.

11. LCD display with full programmable settings

The LCD display shows important parameters such as voltage, current, frequency, load percentage, battery voltage, back-up time, and alarms.

In addition, the display allows the configuration of the following settings: input voltage range, bypass voltage range, output voltage, output frequency, and battery capacity.

12. Parallel and Redundant Operation

Two or more UPS units can be connected in parallel for capacity growth and/or for redundancy.

- Capacity Growth: Several UPS can be connected in parallel to increase the total capacity of the system.
- Redundancy: All units in this system share the total load equally. If one of the UPS fails, or is under maintenance, the remaining UPS continue supporting the total load without interruption.

13. Static and Manual (Maintenance) Bypass

Static Bypass provides safe transfer to mains if the UPS are overloaded or develop a fault condition. During normal system operation, the load is connected to the inverter, however, in the event of a UPS overload or internal failure, the load is automatically transferred to the Static Bypass line without interruptions.

Most units include Manual Bypass switch in order to transfer to utility power without interrupting the power to the load, thus enabling to work safely on a faulty UPS.

14. Generator compatible

The UPS through its robust IGBT rectifier has full compatibility with generators and ensures clean uninterrupted power to the loads.



STAND ALONE CHALLENGER SERIES

1, 2, 3 KVA

SINGLE PHASE

FEATURES:

- Stand alone and rack-mount UPS
- True on-line double conversion technology
- Wide-input voltage range for harsh environments
- Input Power Factor correction 0.99
- Output power factor 0.9
- IGBT PWM rectifier & inverter technology
- Automatic bypass for fault tolerance
- Frequency converter mode
- Energy-saving, ECO mode operation
- Generator compatible
- Friendly LCD Display
- Selectable output voltage via LCD panel
- Multiple communication ports:
USB/ RS-232 and SNMP (optional)

BENEFITS:

- High uptime
- High efficiency, energy-saving ECO mode
- Extends battery lifespan
- Microprocessor control optimizes reliability
- Ease of maintenance
- User-friendly and programmable



**TECHNICAL SPECIFICATIONS:
CHALLENGER SERIES 1, 2, 3 KVA
SINGLE PHASE**



MODEL	SA1P1LVW/SA1P1HVW	SA1P2LVW/SA1P2HVW	SA1P3LVW/SA1P3HVW
Phase	Single phase with ground		
Capacity	1000 VA / 900 W	2000 VA / 1800 W	3000 VA / 2700 W
INPUT			
Nominal Voltage	100/110/115/120/127 VAC or 200/208/220/230/240 VAC		
Voltage Range	60-150 VAC or 120-300 VAC @ 50% load		
	90-140 VAC or 180-280 VAC @ 100% load		
Frequency Range	40-70 Hz (Selectable)		
Power Factor	≥ 0.99, Nominal Voltage (100% load)		
Rectifier	IGBT		
OUTPUT			
Output Voltage	100/110/115/120/127 VAC or 200/208/220/230/240 VAC		
Voltage Regulation	± 1%		
Frequency Range (Synchronized Range)	47 - 53 Hz or 57 - 63 Hz		
Frequency Range (Batt. Mode)	50/60 Hz ± 0.5 %		
Current Crest Ratio	3:1		
Harmonic Distortion (THDv)	Linear Load ≤ 3 % ; Non-linear Load ≤ 6 %		
Transfer Time	Zero (AC to DC) ; 4 ms (Inverter to Bypass)		
Waveform	Pure Sine Wave		
EFFICIENCY			
AC Mode	88%	89%	90%
Battery Mode	83%	85%	88%
BATTERY			
Battery Type	12V/9 Ah		
Numbers	2	4	6
Typical Recharge Time	4 hours recover to 90% capacity		
Charging Current	1.0 A		
Charging Voltage	27.4VDC ± 1%	54.7 VDC ±1%	82.1 VDC ±1%
INDICATORS			
LCD Display	Load level, Battery level, AC mode, Battery mode, Bypass mode, and Fault indicators		
ALARM			
Battery Mode	Sounding every 4 seconds		
Low Battery	Sounding every seconds		
Overload	Sounding twice every second		
Fault	Continuously sounding		
PHYSICAL			
Dimensions (DxWxH) (mm)	282 x 145 x 220	397 x 145 x 220	421 x 190 x 318
Net Weight (kg)	9,8	17	27,6
ENVIRONMENT			
Running Humidity & Temperature	20 - 90 % RH (Non-condensing) @ 0 - 40°C		
Noise Level	< 50 dB @ 1 meter		
MANAGEMENT			
Smart RS-232 /USB	Supports Windows® 2000/2003/XP/Vista/2008, Windows®7/8, Linux, Unix and MAC		
Optional SNMP	Power management from SNMP manager and web browser		
STANDARDS & CERTIFICATIONS			
Quality	ISO 9001 ; ISO 14001		
Compliance	EN62040-3 ; EN61000 ; EN62040-2:2006 ; EN62040-1: 2008 ; CE		

* Derate to 80% of capacity in Frequency converter mode and to 80% when the output voltage is adjusted to 100/200/208 VAC

Sy-G reserves the right to change or modify product design, construction, specifications, or materials without prior notice and without incurring any obligation to make such changes and modifications on Sy-G products previously or subsequently sold.





STAND ALONE CONTENDER SERIES

1, 1.5, 2, 3 KVA

SINGLE PHASE

FEATURES:

- Stand Alone and rack-mount operation
- True on-line double conversion technology
- Wide-input voltage range for harsh environments
- Input power factor correction 0.99
- Output power factor 0.9
- IGBT PWM rectifier & inverter technology
- Automatic bypass for fault tolerance
- Frequency Converter Mode
- Energy saving, ECO mode operation
- Generator compatible
- Friendly LCD Display
- Selectable output voltage via LCD panel
- Multiple communication ports: USB/ RS-232 and SNMP (Optional)
- Emergency power off function (EPO)
- Programmable power management outlets
- Hot swappable battery design (only for rack UPS)
- 3-stage smart charging design
- Maximum 8A extended parallel control available for long run model
- Very high surge immunity up to 7KV, 13KA, 1300J

BENEFITS:

- High uptime
- High efficiency, energy-saving ECO mode
- Extends battery lifespan
- Microprocessor control optimizes reliability
- Ease of maintenance
- User-friendly and programmable



**TECHNICAL SPECIFICATIONS:
CONTENDER SERIES 1, 1.5, 2, 3 KVA
STAND ALONE**



MODEL		SA1P1LVG2/ SA1P1HVG2	SA1P1.5LVG2/SA1P1.5HVG2	SA1P2LVG2/ SA1P2HVG2	SA1P3LVG2/ SA1P3HVG2
Phase		Single phase with ground			
Capacity		1000 VA/900 W	1500 VA/1350 W	2000 VA/1800 W	3000 VA/2700 W
INPUT					
Nominal Voltage		100/110/115/120/127 VAC or 200/208/220/230/240 VAC			
Voltage Range		55 - 150 VAC \pm 5 % or 110 - 300 VAC \pm 5 % at 50% load 80 - 150 VAC \pm 5 % or 160 - 300 VAC \pm 5 % at 100% load			
Frequency Range		40 Hz \sim 70 Hz			
Power Factor		\geq 0.99 @ Nominal Voltage (100% Load) \leq 5% @ 100~130VAC or 205-245VAC			
Harmonic Distortion (THDi)		$<$ 1.6% @ input and full linear load condition with battery fully charged			
Rectifier		IGBT			
OUTPUT					
Output Voltage		100/110/115/120/127 VAC or 200/208/220/230/240 VAC			
AC Voltage Regulation (Batt. Mode)		\pm 1%			
Frequency Range (Synchronized Range)		47~53 Hz or 57~63 Hz			
Frequency Range (Batt. Mode)		50 Hz \pm 0.1 Hz or 60Hz \pm 0.1 Hz			
Current Crest Ratio		3:1			
Harmonic Distortion (THDv)		\leq 2 % THD (Linear Load); \leq 4 % THD (Non-linear Load)			
Transfer Time		Zero (AC to DC); 4 ms (Inverter to Bypass)			
Waveform		Pure Sinewave			
EFFICIENCY					
AC Mode		90%		91%	
ECO Mode		97%			
Battery Mode		89%	89%	89%	90%
BATTERY					
Standard Model	Battery Type	12 V / 7 Ah	12 V / 9 Ah	12 V / 7 Ah	12 V / 9 Ah
	Numbers	3	3	6	8
	Typical Recharge Time	4 hours recover to 90% capacity			
	Charging Current	1.5 A			
Long-run Model	Battery Type	Depending on the capacity of external batteries			
	Numbers	3	3	6	8
	Charging Current	1A/2A/4A/6A/8A (Selectable via LCD setting)			
	Charging Voltage	41.0 VDC \pm 1%	82.1 VDC \pm 1%		109.6VDC \pm 1%
INDICATORS					
LCD Display		UPS status, Load level, Battery level, Input/Output voltage, Discharge timer, and Fault conditions			
ALARM					
Battery Mode		Sounding every 5 seconds			
Low Battery		Sounding every 2 seconds			
Overload		Sounding every second			
Fault		Continuously sounding			
PHYSICAL					
Standard Model	Dimension, DxWxH (mm)	397 x 145 x 220		421 x 190 x 318	
	Net Weight (kgs)	12.5	13.8	25.8	32.8
Long-run Model	Dimension, DxWxH (mm)	397 x 145 x 220		421 x 190 x 318	
	Net Weight (kgs)	5.8	5.8	12	13.8
ENVIRONMENT					
Running Humidity & Temperature		20-95 % RH @ 0- 40°C (Non-condensing)			
Noise Level		Less than 50dB@1Meter			
MANAGEMENT					
Smart RS-232/USB		Supports Windows 2000/2003/XP/Vista/2008, Windows 7/8, Linux, Unix, and MAC			
Optional SNMP		Power management from SNMP manager and web browser			
STANDARDS & CERTIFICATIONS					
Quality		ISO 9001 ; ISO 14001			
Compliance		EN62040-3 ; EN61000 ; EN62040-2:2006 ; EN62040 -1: 2008 ; CE			

*Derate to 80% of capacity in Frequency converter mode and to 80% when the output voltage is adjusted to 100VAC,200VAC or 208 VAC.

** L means long-run model

Sy-G reserves the right to change or modify product design, construction and specifications, without prior notice and without incurring any obligation to make such changes and modifications on Sy-G products previously or subsequently sold.



STAND ALONE AVENGER SERIES

1, 1.5, 2, 3 KVA

SINGLE PHASE

FEATURES:

- Stand Alone and rack-mount operation
- True on-line double conversion technology
- Wide-input voltage range for harsh environments
- Input power factor correction 0.99
- Output power factor 1
- IGBT PWM rectifier & inverter technology
- Automatic bypass for fault tolerance
- Frequency Converter Mode
- Energy saving, ECO mode operation
- Generator compatible
- Friendly LCD Display
- Selectable output voltage via LCD panel
- Multiple communication ports: USB/ RS-232 and SNMP (Optional)
- Emergency power off function (EPO)
- Programmable power management outlets (only for rack UPS)

BENEFITS:

- High uptime
- High efficiency, energy-saving ECO mode
- Extends battery lifespan
- Microprocessor control optimizes reliability
- Ease of maintenance
- User-friendly and programmable
- Hot swappable battery design (only for rack UPS)
- Smart battery charger design to optimize battery performance
- High power factor charger up to 1000W capacity with very low ripple current when charging battery



**TECHNICAL SPECIFICATIONS:
AVENGER SERIES 1, 1.5, 2, 3 KVA
STAND ALONE**



MODEL	SA1P1LVGO / SA1P1HVGO		SA1P1.5LVGO / SA1P1.5HVGO		SA1P2LVGO / SA1P2HVGO			SA1P3LVGO / SA1P3HVGO	
Phase	Single phase with ground								
Capacity*	1000 VA / 1000 W		1500 VA / 1500 W		2000 VA / 2000 W			3000 VA/3000 W	
INPUT									
Nominal Voltage	100/110/115/120/127 VAC or 200/208/220/230/240 VAC								
Voltage Range	55-150 VAC ±3% or 110-300 VAC ±3% @ 50% load 80-150 VAC ±3% or 160-300 VAC ±3% @ 100% load								
Frequency Range	40-70 Hz (Selectable)								
Power Factor	At Full Load ≥ 0.99								
Harmonic Distortion (THDi)	≤ 5%								
Rectifier	IGBT								
OUTPUT									
Output Voltage	100*/110*/115*/120/127 VAC or 200*/208*/220/230/240 VAC								
AC Voltage Regulation (Batt. Mode)	± 1%								
Frequency Range (Synchronized Range)	47-53 Hz or 57-63 Hz								
Frequency Range (Batt. Mode)	50 Hz ± 0.1 Hz or 60 Hz ± 0.1 Hz								
Current Crest Ratio	3:1								
Harmonic Distortion (THDv)	Linear Load ≤ 2% ; Non-linear Load ≤ 4%								
Transfer Time	Zero (AC to DC) ; 4 ms (Inverter to Bypass); 8 ms (Typical), 10 ms (max)								
Waveform	Pure Sine Wave								
Efficiency									
AC Modo	≥ 89% @ battery full charged				≥ 91% @ battery full charged				
ECO Mode	≥ 96% @ battery full charged								
Battery Mode	≥ 88%				≥ 90%				
BATTERY									
Battery Type	9 Ah	7 Ah	9 Ah	9 Ah	7 Ah	7 Ah	9 Ah	7 Ah	
Numbers	2	3	3	4	6	8	6	8	
Typical Recharge Time	3 hours recover to 95% capacity for internal battery @ 2A charging current								
Charging Current	100/110/115/120/127 VAC models: default 2A, max. 8A adjustable 200/208/220/230/240 VAC models: default 2A, max. 12A adjustable				Default 2 A; max. 8A adjustable				
Charging Voltage	27.4 VDC ±1%	41.1 VDC ±1%	41.1 VDC ±1%	54.8 VDC ±1%	82.1 VDC ±1%	109.6 VDC ±1%	82.2 VDC ±1%	109.6 VDC ±1%	
INDICATORS									
LCD Display	Load level, Battery level, AC mode, Battery mode, and Fault indicator								
ALARM									
Battery Mode	Sounding every 5 seconds								
Low Battery	Sounding every 2 seconds								
Overload	Sounding every second								
Fault	Continuously sounding								
PHYSICAL									
Dimensions (DxWxH) (mm)	397 x 145 x 220				421 x 190 x 318				
Net Weight (without battery) (kg)	6.6	6.6	7	9.9	9.9	9.9	12.3	12.3	
Net Weight (w/built-int battery) (kg)	11.7	13	14.6	20.3	23.2	28.5	28	33	
ENVIRONMENT									
Running Humidity & Temperature	20 - 90 % RH (Non-condensing) @ 0 - 40°C								
Noise Level	< 50 dB @ 1 meter con control de velocidad de ventilador								
MANAGEMENT									
Smart RS-232 /USB	Supports Windows® 2000/2003/XP/Vista/2008, Windows®7/8, Linux, Unix and MAC								
Optional SNMP	Power management from SNMP manager and web browser								
STANDARDS & CERTIFICATIONS									
Quality	ISO 9001 ; ISO 14001								
Compliance	EMC 1-1.5K; EN62040-2 C1; 2K-3K EN62040-2 C2								

* Derate capacity to 80% when the output voltage is adjusted to 100VAC/200VAC/208VAC.

SY-G reserves the right to change or modify product design, construction, specifications, or materials without prior notice and without incurring any obligation to make such changes and modifications on SY-G products previously or subsequently sold.



RACK MOUNT CHALLENGER SERIES

1, 1.5, 2, 3 KVA

SINGLE PHASE

FEATURES:

- Rack-mount UPS
- True on-line double conversion technology
- IGBT PWM rectifier & inverter technology
- Pure sine wave output
- Intelligent microprocessor and advanced digital control
- High-input power factor >0.99
- Frequency converter mode
- Programmable power management outlets
- Emergency Power Off (EPO) function
- Energy-saving, ECO mode operation
- Multiple communication ports: USB/ RS-232 and SNMP (optional)
- Smart battery charger design for optimized performance
- Hot-swappable battery design
- Wide-input voltage range for harsh environments
- Automatic bypass for fault tolerance
- Generator compatible
- LCD display with full programmable settings
- Selectable output voltage via LCD panel

BENEFITS:

- High uptime
- High efficiency, energy-saving ECO mode
- Low distortion to utility power
- Extends battery lifespan
- Ease of maintenance
- User-friendly and programmable



**TECHNICAL SPECIFICATIONS:
CHALLENGER SERIES 1, 2, 3 KVA
RACK MOUNT**



MODEL	RM1P1LVW/RM1P1HVW	RM1P2LVW/RM1P2HVW	RM1P3LVW/RM1P3HVW
Phase	Single phase with ground		
Capacity	1000 VA / 900 W	2000 VA / 1800 W	3000 VA / 2700 W
INPUT			
Nominal Voltage	100/110/115/120/127 VAC or 200/208/220/230/240 VAC		
Voltage Range	At 50% load: 120-300 VAC or 60-145 VAC		
	At 100% load: 180-280 VAC or 90-145 VAC		
Power Factor	≥ 0.99, Nominal Voltage (100% load)		
Frequency Range	40-70 Hz (Selectable)		
Rectifier	IGBT		
OUTPUT			
Output Voltage	100/110/115/120/127 VAC or 200/208/220/230/240 VAC		
Voltage Regulation	± 1%		
Frequency Range (Synchronized Range)	47 - 53 Hz or 57 - 63 Hz		
Frequency Range (Batt. Mode)	50 Hz ± 0.25 Hz or 60 Hz ± 0.3 Hz		
Current Crest Ratio	3:1		
Harmonic Distortion (THDv)	Linear Load ≤ 3 % ; Non-linear Load ≤ 6 %		
Transfer Time	Zero (AC to DC) ; 4 ms (Inverter to Bypass)		
Waveform	Pure Sine Wave		
EFFICIENCY			
AC Mode	88%	89%	90%
Battery Mode	83%	87%	88%
BATTERY			
Battery Type	12V/ 9 Ah		
Numbers	2	4	6
Typical Recharge Time	4 hours recover to 90% capacity		
Charging Current	1.0 A		
Charging Voltage	27.4VDC ± 1%	54.7 VDC ± 1%	82.1 VDC ± 1%
INDICATORS			
LCD Display	UPS status, load level, Battery level, Input/Output voltage, Discharge timer, and Fault conditions		
ALARM			
Battery Mode	Sounding every 4 seconds		
Low Battery	Sounding every seconds		
Overload	Sounding twice every second		
Fault	Continuously sounding		
PHYSICAL			
Dimensions (DxWxH) (mm)	310 x 438 x 88	410 x 438 x 88	630 x 438 x 88
Net Weight (kg)	12	19	29.3
ENVIRONMENT			
Running Humidity & Temperature	20 - 90 % RH (Non-condensing) @ 0 - 40°C		
Noise Level	< 50 dB @ 1 meter		
MANAGEMENT			
Smart RS-232 /USB	Supports Windows® 2000/2003/XP/Vista/2008, Windows® 7/8, Linux, Unix and MAC		
Optional SNMP	Power management from SNMP manager and web browser		
STANDARDS & CERTIFICATIONS			
Quality	ISO 9001 ; ISO 14001		
Compliance	EN62040-3 ; EN61000 ; EN62040-2:2006 ; EN62040 -1: 2008 ; CE		

* Derate to 80% of capacity in Frequency converter mode and to 80% when the output voltage is adjusted to 100/200/208 VAC

SY-G reserves the right to change or modify product design, construction, specifications, or materials without prior notice and without incurring any obligation to make such changes and modifications on SY-G products previously or subsequently sold.



RACK MOUNT CONTENDER SERIES

1, 1.5, 2, 3 KVA

STAND ALONE

FEATURES:

- Rack-mount UPS
- True on-line double conversion technology
- IGBT PWM rectifier & inverter technology
- Pure sine wave output
- Intelligent microprocessor and advanced digital control
- High-input power factor >0.99
- Frequency converter mode
- Programmable power management outlets
- Emergency Power Off (EPO) function
- Energy-saving, ECO mode operation
- Multiple communication ports: USB/ RS-232 and SNMP (optional)
- Smart battery charger design for optimized performance
- Hot-swappable battery design
- Wide-input voltage range for harsh environments
- Automatic bypass for fault tolerance
- Generator compatible
- LCD display with full programmable settings
- Selectable output voltage via LCD panel

BENEFITS:

- High uptime
- High efficiency, energy-saving ECO mode
- Low distortion to utility power
- Extends battery lifespan
- Ease of maintenance
- User-friendly and programmable



**TECHNICAL SPECIFICATIONS:
CONTENDER SERIES 1, 1.5, 2, 3 KVA
RACK MOUNT**



MODEL		RM1P1LVG2/ RM1P1HVG2	RM1P1.5LVG2/ RM1P1.5HVG2	RM1P2LVG2/ RM1P2HVG2	RM1P3LVG2/ RM1P3HVG2		
Phase		Single phase with ground					
Capacity*		1000 VA/900 W	1500 VA/1350 W	2000 VA/1800 W	3000 VA/2700 W		
INPUT							
Nominal Voltage		100*/110*/115*/120/127 VAC or 200/208/220/230/240 VAC					
Voltage Range		55-150 VAC ± 5% or 110-300 VAC ± 5% @ 50% load 80-150 VAC ± 5% or 160-300 VAC ± 5% @ 100% load					
Frequency Range		40 Hz ~ 70 Hz					
Power Factor		≥ 0.99 @ nominal voltage (100% load)					
Harmonic Distortion(THDi)		≤ 5% @ nominal input voltage					
Rectifier		IGBT					
OUTPUT							
Output Voltage		100*/110*/115*/120/127 VAC or 200/208/220/230/240 VAC					
AC Voltage Regulation (Batt. Mode)		± 1%					
Frequency Range (Synchronized Range)		57 ~ 63 Hz or 47 ~ 53 Hz					
Frequency Range (Batt. Mode)		60Hz ± 0.1Hz or 50 Hz ± 0.1Hz					
Current Crest Ratio		3:1 (max.)					
Harmonic Distortion (THDv)		≤ 2 % THD (Linear Load) ; ≤ 4 % THD (Non-Linear load)					
Transfer Time		Zero (AC to DC); 4 ms (Inverter to Bypass)					
Waveform		Pure Sinewave					
EFFICIENCY							
AC Mode		90%	90%	91%	91%		
ECO Mode		97%	97%	97%	97%		
Battery Mode		88%	89%	88%	89%	90%	
BATTERY							
Standard Model	Battery Type	12 V / 9 Ah	12 V / 7 Ah	12 V / 9 Ah	12 V / 7 Ah	12 V / 7 Ah	12 V / 9 Ah
	Numbers	2	3	3	4	6	6
	Typical Recharge Time	4 hours recover to 90% capacity					
	Charging Current	1.5 A**					
Long-run Model	Charging Voltage	27.4 VDC ± 1%	41.1 VDC ± 1%	41.1 VDC ± 1%	54.8 VDC ± 1%	82.1 VDC ± 1%	82.1 VDC ± 1%
	Battery Type	Depending on the capacity of external batteries					
	Numbers	2	3	3	4	6	6
	Charging Current	1A/2A/4A/8A (Selectable via LCD setting)					
Long-run Model	Charging Voltage	27.4 VDC ± 1%	41.1 VDC ± 1%	41.1 VDC ± 1%	54.8 VDC ± 1%	82.1 VDC ± 1%	82.1 VDC ± 1%
	Charging Voltage	27.4 VDC ± 1%	41.1 VDC ± 1%	41.1 VDC ± 1%	54.8 VDC ± 1%	82.1 VDC ± 1%	82.1 VDC ± 1%
INDICATORS							
LCD Display		UPS status, Load level, Battery level, Input/Output voltage, Discharge timer, and Fault conditions					
ALARM							
Battery Mode		Sounding every 5 seconds					
Low Battery		Sounding every 2 seconds					
Overload		Sounding every second					
Fault		Continuously sounding					
PHYSICAL							
Standard Model	Dimension, DxWxH (mm)	410 x 438 x 88		410 x 438 x 88	510x438x88	630x438x88	630 x 438 x 88
	Net Weight (kgs)	11.6	14.2	14.5	19.5	26.9	27.4
Long-run Model	Dimension, DxWxH (mm)	410 x 438 x 88		410 x 438 x 88	410x438x88		510 x 438 x 88
	Net Weight (kgs)	6.4		6.5	6.5		10.5
ENVIRONMENT							
Running Humidity & Temperature		20-90 % RH @ 0- 40°C (Non-condensing)					
Noise Level		Less than 50dB @ 1 Meter					
MANAGEMENT							
Smart RS-232/USB		Supports Windows® 2000/2003/XP/Vista/2008, Windows® 7/8, Linux, Unix, and MAC					
Optional SNMP		Power management from SNMP manager and web browser					
STANDARDS & CERTIFICATIONS							
Quality		ISO 9001 ; ISO 14001					
Compliance		EN62040-3 ; EN61000 ; EN62040-2:2006 ; EN62040 -1: 2008 ; CE					

*Derate capacity to 95% when the output voltage is adjusted to 115VAC, derate capacity to 90% when the output voltage is adjusted to 110VAC and derate capacity to 80% when the output voltage is adjusted to 100VAC/200VAC/208VAC.

**If standard UPS is equipped with additional charger, the available setting options become 2A, 3A and 4A.

SY-G reserves the right to change or modify product design, construction and specifications, without prior notice and without incurring any obligation to make such changes and modifications on SY-G products previously or subsequently sold.



RACK MOUNT AVENGER SERIES

1, 1.5, 2, 3 KVA

TWO PHASE

FEATURES:

- Rack-mount UPS
- True on-line double conversion technology
- IGBT PWM rectifier & inverter technology
- Pure sine wave output
- Intelligent microprocessor and advanced digital control
- High-input power factor >0.99
- Frequency converter mode
- Programmable power management outlets
- Emergency Power Off (EPO) function
- Energy-saving, ECO mode operation
- Multiple communication ports: USB/ RS-232 and SNMP (optional)
- Smart battery charger design for optimized performance
- Hot-swappable battery design
- Wide-input voltage range for harsh environments
- Automatic bypass for fault tolerance
- Generator compatible
- LCD display with full programmable settings
- Selectable output voltage via LCD panel

BENEFITS:

- High uptime
- High efficiency, energy-saving ECO mode
- Low distortion to utility power
- Extends battery lifespan
- Ease of maintenance
- User-friendly and programmable

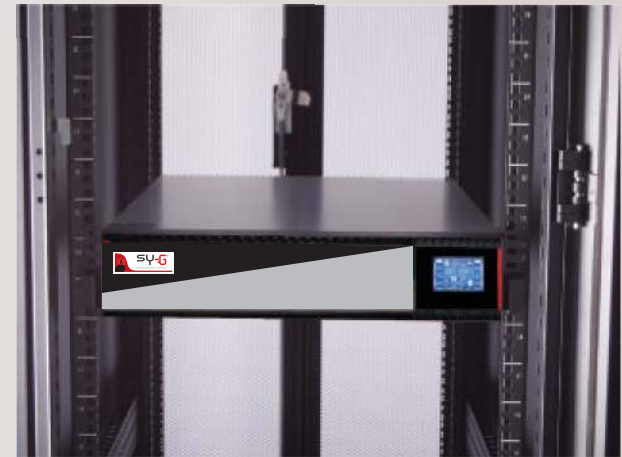

**TECHNICAL SPECIFICATIONS:
AVENGER SERIES 1, 1.5, 2, 3 KVA
RACK MOUNT**



MODEL	RM1P1LVGO / RM1P1HVGO	RM1P1.5LVGO / RM1P1.5HVGO	RM1P2LVGO / RM1P2HVGO	RM1P3LVGO / RM1P3HVGO		
Phase	Single phase with ground					
Capacity*	1000 VA / 1000 W	1500 VA / 1500 W	2000 VA / 2000 W	3000 VA/3000 W		
INPUT						
Nominal Voltage	100/110/115/120/127 VAC or 200/208/220/230/240 VAC					
Voltage Range	55-150 VAC ±5% or 110-300 VAC ±5% @ 50% load 80-150 VAC ±5% or 160-300 VAC ±5% @ 100% load					
Frequency Range	40-70 Hz (Selectable)					
Power Factor	At Full Load ≥ 0.99					
Harmonic Distortion (THDi)	≤ 5% @ nominal input voltage					
Rectifier	IGBT					
OUTPUT						
Output Voltage	100*/110*/115*/120/127 VAC or 200*/208*/220/230/240 VAC					
AC Voltage Regulation (Batt. Mode)	± 1%					
Frequency Range (Synchronized Range)	57-63 Hz or 47-53 Hz					
Frequency Range (Batt. Mode)	60 Hz ± 0.1 Hz or 50 Hz ± 0.1 Hz					
Current Crest Ratio	3:1 (max)					
Harmonic Distortion (THDv)	Linear Load ≤ 2% ; Non-linear Load ≤ 4%					
Transfer Time	Zero (AC to DC) ; 4 ms (Inverter to Bypass)					
Waveform	Pure Sine Wave					
Efficiency						
AC Modo	≥ 89% @ full charged battery		≥ 91% @ full charged battery			
ECO Mode	≥ 96% @ full charged battery					
Battery Mode	≥ 88%		≥ 90%			
BATTERY						
Battery Type	9 Ah	7 Ah	9 Ah	9 Ah	7 Ah	9 Ah
Numbers	2	3	3	4	6	6
Typical Recharge Time	3 hours recover to 95% capacity for internal battery @ 2A charging current					
Charging Current	100/110/115/120/127 VAC models: default 2A, max. 8A adjustable			Default 2 A; max. 8A adjustable		
	200/208/220/230/240 VAC models: default 2A, max. 12A adjustable					
Charging Voltage	41.1 VDC ±1%	41.1 VDC ±1%	41.1 VDC ±1%	54.8 VDC ±1%	82.1 VDC ±1%	82.1 VDC ±1%
INDICATORS						
LCD Display	UPS status, load level, Battery level, Input/Output voltage, Discharge timer, and Fault conditions					
ALARM						
Battery Mode	Sounding every 5 seconds					
Low Battery	Sounding every 2 seconds					
Overload	Sounding every second					
Fault	Continuously sounding					
PHYSICAL						
Dimensions (DxWxH) (mm)	410 x 438 x 88		410 x 438 x 88	510 x 438 x 88	630 x 438 x 88	630 x 438 x 88
Net Weight (without battery) (kg)	6.6	7.8	8.1	9.4	10.6	12.4
Net Weight (w/built-int battery) (kg)	11.6	14.1	15.5	19.5	23.3	27.5
ENVIRONMENT						
Running Humidity & Temperature	20 - 90 % RH (Non-condensing) @ 0 - 40°C					
Noise Level	< 50 dB @ 1 meter					
MANAGEMENT						
Smart RS-232 /USB	Supports Windows® 2000/2003/XP/Vista/2008, Windows® 7/8, Linux, Unix and MAC					
Optional SNMP	Power management from SNMP manager and web browser					
STANDARDS & CERTIFICATIONS						
Quality	ISO 9001 ; ISO 14001					
Compliance	EMC 1-1.5K; EN62040-2 C1; 2K-3K EN62040-2 C2					

* Derate capacity to 80% when the output voltage is adjusted to 100VAC/200VAC/208VAC.

SY-G reserves the right to change or modify product design, construction, specifications, or materials without prior notice and without incurring any obligation to make such changes and modifications on SY-G products previously or subsequently sold.



STAND ALONE SEEKER SERIES

6, 10 KVA

TWO PHASE

FEATURES:

- True on-line double conversion technology
- IGBT PWM rectifier & inverter technology
- Incorporates two single phase rectifiers and inverters
- Pure sine wave output
- DSP technology guarantees high performance
- Cold start from batteries
- High-input power factor: > 0.99
- Output power factor correction: 0.8
- Frequency converter mode
- Emergency Power Off (EPO) function
- Energy-saving ECO mode operation
- SNMP can be used simultaneously with either USB or RS-232
- Wide-input voltage range for harsh environments
- Automatic bypass for fault tolerance
- Generator compatible
- Maintenance bypass available
- LCD display with programmable settings provides easy monitoring and access to UPS status
- Charger capacity expansion to 8A for long-run models (Optional)
- Paralleling option up to 3 units

BENEFITS:

- Low voltage (120 VAC) and high voltage (220 VAC) loads can be connected without isolation transformer
- Split phase: Each phase can be fully loaded with 50% of the total KVA rating
- Parallel ready
- Phase to phase: Can be loaded with 100% of the KVA rating
- High uptime
- High efficiency with energy-saving ECO mode
- Low distortion to utility power
- Ease of maintenance
- User-friendly and programmable



**TECHNICAL SPECIFICATIONS:
SEEKER SA SERIE
6-10 KVA TWO PHASE**



MODEL	SA2P6LVG	SA2P10LVG
Phase	Two Phase In / Two Phase Out	
Capacity ⁽¹⁾	6000 VA / 4800 W	10000 VA / 8000 W
INPUT		
Input Nominal Voltage	100/110/115/120/127 VAC (P-N) ; 200/208/220/230/240 VAC (P-P) 2P+N+G	
Input Voltage Range	60-150 VAC (Ph-N) VAC (Based on load at 50%) 80-140 VAC (Ph-N) VAC (Based on load at 100%)	
Input Power Factor	At Full Load > 0.99	
Input Frequency Range	50/60 Hz ± 4 Hz (Selectable)	
Rectifier	IGBT	
Phase Angle	0°/120°/180°/240°	
OUTPUT		
Output Voltage Range	100/110/115/120/127 VAC (P-N) ; 200/208/220/230/240 VAC (P-P)	
Output Frequency Regulation	50/60 Hz (Autosensing) 50/60 ± 0.1 Hz (Battery Mode)	
Total Harmonic Distortion (THDv)	Linear Load < 2 % ; Non-linear Load < 5 %	
Crest Factor (CF)	3:1	
Efficiency	89%	
Transfer Time	Zero ms (online system) ; < 4 ms (Inverter to Bypass)	
Waveform	Pure Sine Wave	
BATTERY		
Quantity (12 V DC VRLA)	10 pcs x 2 strings	10 pcs x 4 strings
Type of Battery	9 Ah ; Internal	7 Ah ; External cabinet
Charging Current	2 A	
Charging Voltage	136.5 VDC ±1%	
Typical Recharge Time	5 hours recover to 90% capacity	7 hours recover to 90% capacity
Back-up Time (Full/Half load)	9 / 22 minutes	8 / 21 minutes
COMMUNICATION & MANAGEMENT		
Communication Ports	RS-232 Smart, USB, SNMP Adapter (Optional)	
Communication Cards	SNMP/Web (Optional)	
Compatibility	Supports Windows® 2000/2003/XP/Vista/2008, Windows®7, Linux, Unix, and MAC	
Display	LCD: UPS status, Load level, Battery level, Input/Output voltage, Discharge timer, and Fault	
GENERAL		
Dimensions (WxDxH) (mm)	250 x 592 x 576	250 x 592 x 576 (UPS) 250 x 592 x 576 (Battery Cabinet)
Net Weight (kg)	93	38 (UPS) ; 110 (Battery Cabinet)
Running Humidity & Temperature	0 - 95 % RH (Non-condensing) @ 0 - 40°C	
Storage Temperature	For UPS -25~45°C	
Protection Class	IP20	
Chassis	Antistatic paint protection	
Noise Level	< 55 dB @ 1 meter	< 58 dB @ 1 meter
STANDARDS & CERTIFICATIONS		
Quality	ISO 9001 ; ISO 14001	
Compliance	EN62040-3 ; IEC/EN 61000 ; IEC/EN 60950 ; IEC/EN 62040 ; CE	

(1) — 6-10KVA: Derate to 60% of capacity in Frequency converter mode and to 90% when the output voltage is adjusted to 208 VAC

SY-G reserves the right to change or modify product design, construction, specifications, or materials without prior notice and without incurring any obligation to make such changes and modifications on SY-G products previously or subsequently sold.





RACK MOUNT SEEKER SERIES

6, 10 KVA

TWO PHASE

FEATURES:

- Rack-mount UPS
- True on-line double conversion technology
- IGBT PWM rectifier & inverter technology
- Pure sine wave output
- Intelligent microprocessor and advanced digital control
- Cold start from batteries
- High-input power factor: > 0.99
- Frequency converter mode
- Emergency Power Off (EPO) function
- Energy-saving, ECO mode operation
- Multiple communication ports: USB/ RS-232 and SNMP (optional)
- Smart battery charger design for optimized performance
- Charger upgrade for external battery banks (optional)
- Wide-input voltage range for harsh environments
- Automatic bypass for fault tolerance
- Generator compatible
- LCD display with full programmable settings
- Selectable output voltage via LCD panel

BENEFITS:

- High uptime
- High efficiency, energy-saving ECO mode
- Low distortion to utility power
- Extends battery lifespan
- User-friendly and programmable
- Scalability and redundancy
- Paralleling option up to 3 units



**TECHNICAL SPECIFICATIONS:
SEEKER RM SERIES 6-10 KVA
TWO PHASE**



MODEL	SA2P6LVG	SA2P10LVG
Phase	Two Phase In / Two Phase Out	
Capacity ⁽¹⁾	6000 VA / 4800 W	10000 VA / 8000 W
INPUT		
Input Nominal Voltage	100/110/115/120/127 VAC (P-N) ; 200/208/220/230/240 VAC (P-P) 2P+N+G	
Input Voltage Range	60-150 VAC (Ph-N) VAC (Based on load at 50%)	
	80-140 VAC (Ph-N) VAC (Based on load at 100%)	
Input Power Factor	At Full Load > 0.99	
Input Frequency Range	50/60 Hz ± 4 Hz (Selectable)	
Rectifier	IGBT	
Phase Angle	0°/120°/180°/240°	
OUTPUT		
Output Voltage Range	100/110/115/120/127 VAC (P-N) ; 200/208/220/230/240 VAC (P-P)	
Output Frequency Regulation	50/60 Hz (Autosensing)	
	50/60 ± 0.1 Hz (Battery Mode)	
Total Harmonic Distortion (THDv)	Linear Load < 2 % ; Non-linear Load < 5 %	
Crest Factor (CF)	3:1	
Efficiency	89%	
Transfer Time	Zero ms (online system) ; < 4 ms (Inverter to Bypass)	
Waveform	Pure Sine Wave	
BATTERY		
Quantity (12 V DC VRLA)	10 pcs x 2 strings	10 pcs x 4 strings
Type of Battery	9 Ah ; Internal	7 Ah ; External cabinet
Charging Current	2 A	
Charging Voltage	136.5 VDC ±1%	
Typical Recharge Time	5 hours recover to 90% capacity	7 hours recover to 90% capacity
Back-up Time (Full/Half load)	9 / 22 minutes	8 / 21 minutes
COMMUNICATION & MANAGEMEN		
Communication Ports	RS-232 Smart, USB, SNMP Adapter (Optional)	
Communication Cards	SNMP/Web (Optional)	
Compatibility	Supports Windows® 2000/2003/XP/Vista/2008, Windows®7, Linux, Unix, and MAC	
Display	LCD: UPS status, Load level, Battery level, Input/Output voltage, Discharge timer, and Fault	
GENERAL		
Dimensions (WxDxH) (mm)	250 x 592 x 576	250 x 592 x 576 (UPS) 250 x 592 x 576 (Battery Cabinet)
Net Weight (kg)	93	38 (UPS) ; 110 (Battery Cabinet)
Running Humidity & Temperature	0 - 95 % RH (Non-condensing) @ 0 - 40°C	
Storage Temperature	For UPS -25~45°C	
Protection Class	IP20	
Chassis	Antistatic paint protection	
Noise Level	< 55 dB @ 1 meter	< 58 dB @ 1 meter
STANDARDS & CERTIFICATIONS		
Quality	ISO 9001 ; ISO 14001	
Compliance	EN62040-3 ; IEC/EN 61000 ; IEC/EN 60950 ; IEC/EN 62040 ; CE	

(1) — 6-10KVA: Derate to 60% of capacity in Frequency converter mode and to 90% when the output voltage is adjusted to 208 VAC

SY-G reserves the right to change or modify product design, construction, specifications, or materials without prior notice and without incurring any obligation to make such changes and modifications on SY-G products previously or subsequently sold.



STAND ALONE HERO SERIES

10, 20, 30, 40 50, 60 KVA

THREE PHASE

FEATURES:

- True on-line double conversion technology
- IGBT PWM rectifier & inverter technology
- Pure sine wave output
- DSP (Digital Signal Processor) control
- Low-input current THD: <3%
- High-input power factor: >0.99
- High efficiency up to 93%
- Wide-input voltage range
- Advanced Battery Management (ABM)
- Short-circuit and overload protection
- Paralleling option up to 16 units
- Dual input (optional)
- Selectable number of batteries
- 500 real-time event log with detailed parameters
- Static and manual bypass operation
- Energy-saving ECO mode operation
- Communication ports: RS-232/ RS-485 and SNMP (optional)
- Generator compatible
- Customizable as frequency converter
- Graphic display with full programmable settings

BENEFITS:

- High uptime
- High efficiency with energy-saving ECO mode
- Low distortion to utility power
- Extends battery lifespan
- Operating cost savings
- Small footprint and ease of maintenance
- User-friendly and programmable
- Scalability and redundancy
- Parallel ready



SY-G[®]

Empowering New Frontiers™



INDEX

CATEGORY

www.sy-g.com

**TECHNICAL SPECIFICATIONS:
HERO SERIES 10, 20, 30,
40 50, 60 KVA
THREE PHASE**



MODEL	SA3P10LMB	SA3P15LMB	SA3P20LMB	SA3P30LMB	SA3P40LMB	SA3P50LMB	SA3P60LMB
Phase	Three Phase In / Three Phase Out				Three Phase In / Three Phase Out		
Capacity	10 KVA / 8 KW	15 KVA / 12 KW	20 KVA / 16 KW	30 KVA / 24 KW	40 KVA / 32 KW	50 KVA / 40 KW	60 KVA / 48 KW
INPUT							
Input Nominal Voltage ⁽¹⁾	120/208 VAC ; 127/220 VAC 3P+N+G						
Input Voltage Range	-15% + 18%						
Input Power Factor	At Full Load > 0.99						
Input Frequency Range	45 - 65 Hz (Selectable)						
Rectifier	IGBT						
Total Harmonic Distortion (THDi)	< 3%						
OUTPUT							
Output Voltage Range	120/208 VAC ; 127/220 VAC 3P+N+G ± 1%						
Output Frequency Regulation	50/60 Hz (Selectable)						
	50/60 Hz ± 0.01% (Battery Mode)						
Total Harmonic Distortion (THDv)	Linear Load < 2% ; Non-Linear Load < 6%						
Crest Factor (CF)	3:1						
Efficiency	Up to 93% ; Eco Mode 98%						
Transfer Time	Zero						
Waveform	Pure Sine Wave						
Overload Capacity	At 125% Load 10min, at 150% Load 1min						
Recovery	0% - 100% - 0% Step Load, Maximum Output Tolerance 5% ; 1% Back to Band <40ms						
BATTERY							
Quantity (12 V DC VRLA)	2 x 17 per string						
Type of Battery (12 V DC VRLA - Internal)	34 x 9 Ah	34 x 12 Ah	68 x 9 Ah	68 x 10 Ah	External cabinet		
Back-up Time (Full/Half load)	10 / 22 min	9 / 20 min	10 / 22 min	7 / 16 min			
COMMUNICATION & MANAGEMENT							
Communication Ports	RS-232 (standard), SNMP/Web (standard), RS-485 (optional)						
Communication Cards	SNMP/Web (Optional) , ModBus (Optional)						
Protocols	SEC, TELNET						
Compatibility	Supports Windows® 2000/2003/XP/Vista/2008, Windows®7, Linux, Unix, and MAC						
Display	Graphic: Full programmable settings						
Dry Contacts	Optional						
GENERAL							
Dimensions (WxDxH) (mm)	460 x 805 x 1190				880 x 770 x 1660		
Net Weight (kg)	125	150	160	180	300	320	350
Running Humidity & Temperature	UPS: 0 - 95 % RH (Non-condensing) @ 0 - 40°C ; Bat. 0 - 25°C						
Storage Temperature	-10~45°C						
Protection Class	IP20						
Chassis	Anti-Static Paint Protection						
Alarms	500 Event Log.						
Parallel Operation	Parallel Power Increase up to 16 pcs.						
EPO (Emergency Power Off)	Standard						
Isolation Transformer	Optional						
STANDARDS & CERTIFICATIONS							
Quality	ISO 9001 ; ISO 14001 ; ISO 18001						
Compliance	EN62040 - 3 ; EN62040 - 2 ; EN62040 - 1 ; EN60950 ; CE ; UL						

(1) — 380 - 400 - 415 VAC (Ph-Ph) Versions are available; some specifications may vary, please refer to our web-site.

SY-G reserves the right to change or modify product design, construction, specifications, or materials without prior notice and without incurring any obligation to make such changes and modifications on SY-G products previously or subsequently sold.





STAND ALONE VIRTUOSO SERIES

10, 15, 20, 30, 50, 60, 80, 100,
125, 150, 200, 250 KVA

THREE PHASE

FEATURES:

- Three Level Rectifier & Inverter Technology
- Output Power Factor 1 (kVA=KW)
- On Line-Double Conversion Technology (Class VFI-SS-111)
- IGBT PWM Rectifier & Inverter Technology
- DSP Control
- High Efficiency up to 96%
- Low Input Current THD (<3%)
- High Input Power Factor (>0.99)
- Dual Input
- Optional DC/DC Charger/Booster
- Wide Input Voltage Range (Optional)
- Advanced Battery Management
- Short Circuit and Overload Protection
- Parallellable Modules up to 8 units
- 500 Real Time Event Log with Detailed Parameters
- Static & Manual Bypass Operation
- Overload and Short Circuit Protection
- Small Footprint and Easy Maintenance
- Advanced Communication Capabilities
- Perfect Generator Compatibility

BENEFITS:

- High uptime
- High efficiency with energy-saving ECO mode
- Low distortion to utility power
- Extends battery lifespan
- Operating cost savings
- Small footprint and ease of maintenance
- User-friendly and programmable
- Scalability and redundancy
- Parallel ready



**TECHNICAL SPECIFICATIONS:
VIRTUOSO SERIES 10, 15, 20, 30, 50,
60, 80, 100, 125, 150, 200, 250 KVA**



MODELS	SA3P10LML	SA3P15LML	SA3P20LML	SA3P30LML	SA3P40LML	SA3P50LML	SA3P60LML	SA3P80LML	SA3P100LML	SA3P125LML	SA3P150LML	SA3P200LML	SA3P250LML
Phase	Three Phase In / Three Phase Out												
Capacity	10KVA/10KW	15 KVA/15KW	20KVA/20KW	30KVA/30KW	40KVA/40KW	50KVA/50KW	60KVA/60KW	80KVA/80KW	100KVA/100KW	125KVA/125KW	125KVA/125KW	200KVA/200KW	250KVA/250KW
INPUT													
Input Nominal Range	120/208 VAC; 3P+N+G												
Input Voltage Range	-15% + 18% Optional -37% +22%												
Input Power Factor	At Full Load ≥ 0.99												
Input Frequency Range	45 - 65 Hz (Selectable)												
Rectifier	Three Level IGBT Technology												
Total Harmonic Distortion (THDi)	<3%												
OUTPUT													
Output Voltage Range	120 / 208 VAC; 127/ 220 VAC 3P+N+G ±1%												
Output Frequency Range	50/60 Hz ± 0.5% Synchronous with the Network												
	50/60 Hz ± 0.2% Battery Mode												
Total Harmonic Distortion (THDv)	Linear Load < 2% ; Non-Linear Load < 5%												
Crest Factor (CF)	3:1												
Efficiency	96%, Eco Mode 98%												
Inverter	Three Level IGBT Technology, Pure Sine Wave												
Overload Capacity	At 125% Load 10min; at 150% Load 1min												
Recovery	0% - 100% - 0% Load, Maximum Output Tolerance 5%, 1% Back to Band <40ms												
BATTERY													
Quantity (12V DC VRLA)	2X17												
Type of battery	2X34X9AH	External, Maintenance free sealed batteries											
COMMUNICATION & MANAGEMENT													
Communication Ports	RS-232 (standard), SNMP (optional), RS-485 (optional)												
Communication Cards	SNMP (Optional) , ModBus (Optional)												
Protocols	SEC, TELNET												
Compatibility	Supports Windows® 2000/2003/XP/Vista/2008, Windows®7, Linux, Unix, and MAC												
Display	320 x 240 Touch Panel LCD Graphic Display												
Dry Contacts	Optional												
GENERAL													
Dimensions (WxDxH) (mm)	490x805x1190			763x771x1555		810x820x1705		830x870x1800			1480x850x1790		
Net Weight (kg)	107	118	125	260	270	350	355	450	485	650	700	850	1350
Running Temperature	For UPS 0°C - 40°C For Battery 0°C - 25°C												
Storage Temperature	For UPS 15°C - 45°C For Batteries -10°C - 60°C												
Humidity	0-95%												
Protection Class	IP20												
Chassis	Anti-Static Paint Protection												
Alarms	500 Event Log												
Parallel Operation	Parallel Power Increase up to 8pcs.												
EPO (Emergency Power Off)	Standard												
Isolation Transformer	Optional												
STANDARDS & CERTIFICATIONS													
Quality	ISO 9001 ; ISO 14001 ; ISO 18001												
Compliance	EN62040 -3 (VFI-SS-111); EN62040 - 2 ; EN62040 -1 ; EN60950 ; CE												

Sy-G reserves the right to change or modify product design, construction, specification or materials without previous notice and without incurring any obligation to make such changes and modifications on Sy-G products previously or subsequently sold. Sy-G do not guarantee the items of the accuracy and completeness.





MODULAR MAVERICK SERIES

10-100 KVA / KW
(Modular UPS)

THREE PHASE

FEATURES:

- Modular UPS: N+X redundancy, hot plugging for system updates or capacity expansion
- True on-line double conversion technology
- High reliability design based on IGBT modules in rectifier & inverter (three-level topology)
- Green and energy-saving power supply; overall efficiency: >95%
- Pure sine wave output
- High-input power factor: >0.99; Low-input THDi: <3%
- Output power factor: 1
- Frequency converter mode
- Hot Swap Plug-In Module
- Strong adaptability for linear and non-linear loads
- Intelligent module and system protection design
- Low noise generation
- Double DSP (Digital Signal Processor) controller for independent control of each power module, no single-point of failure
- Redundancy and adjustable-speed fan, low noise, low power consumption
- Battery cold start module
- Built-in breakers for cabinet input, output and maintenance connection
- Large graphic touch-screen LCD offering extensive information
- Independent charging system, strong charging capacity, perfect battery management scheme.
- Digital paralleling technology; very low circulation current between modules
- Complete frontal access, top and bottom cable connections
- User-friendly generator interface
- Paralleling options up to 2 units, in order to reach a maximum of 200 KVA
- Two chassis versions: 10 slots and 6 slots
- Optional: SNMP card, battery temperature compensation module, parallel kit



BENEFITS:

- Modularity for very flexible service
- High uptime
- High efficiency with energy-saving ECO mode
- Low distortion to utility power
- Extends battery lifespan
- Ease of installation and maintenance due to its hot swappable feature
- User-friendly and programmable
- Scalability and redundancy
- Higher efficiency, higher frequency modulation and smaller size due to its inverter design
- Easy to install even close to other equipment; space-saving footprint in service room



**TECHNICAL SPECIFICATIONS:
MAVERICK SERIES 10-100 KVA / KW
THREE PHASE**



MODEL	MO3P60/6LIR	MO3P100/10LIR
Phase	Three Phase In / Three Phase Out	
Capacity	Grows from 10 to 60 KVA / KW	Grows from 10 to 100 KVA / KW
INPUT		
Input Nominal Voltage	208/220 VAC (line to line)	
Input Voltage Range	-40% ~ 20%	
Input Power Factor	At Full Load > 0.99	
Input Frequency Range	40 - 70 Hz (Selectable)	
Rectifier	IGBT	
Total Harmonic Distortion (THDi)	< 3%	
OUTPUT		
Output Voltage Range	208/220 VAC \pm 1% (at balanced load)	
Output Frequency Regulation	50 - 60 Hz (Selectable)	
Power Factor	1	
Total Harmonic Distortion (THDv)	Linear Load < 1% ; Non-linear Load < 3%	
Crest Factor (CF)	3:1	
Efficiency	95% (ECO Mode 98%)	
Transfer Time	Zero	
Waveform	Pure Sine Wave	
Overload Capacity	At 105% Long time operation, at 110% Load 60 min, 125% Load 10 min, at 150% Load 1 min, >150% 200 ms	
BATTERY		
Quantity (12 V DC VRLA)	2 x 10 per string	
Type of Battery	External Battery cabinet (Option 1) or Modular Battery cabinet (Option 2)	
Nominal Voltage	\pm 120 VDC	
Charge Power	0-20% of The Device Power (Selectable)	
Back-up time (Full/Half load)	Depending on the configuration of electronic and battery modules	
COMMUNICATION & MANAGEMENT		
Communication Ports	RS-232, RS-485, SNMP, EPO, Generator Interface	
Compatibility	Supports Windows® 2000/2003/XP/Vista/2008, Windows®7, Linux, Unix, and MAC	
Display	Graphic LCD+LED, Touch screen and keyboard	
Dry Contacts	Included	
GENERAL		
Dimensions UPS Modules & Cabinets (WxDxH) (mm)	600 x 900 x 1600 - 6 slot UPS Cabinet	600 x 900 x 2000 - 10 slot UPS Cabinet
	440 x 590 x 134 10KVA/KW Electronic Module	
Dimensions Battery Modules & Cabinets (WxDxH) (mm)	Battery Configured in Accordance to required Backup Time	
	187kg UPS Cabinet	214kg UPS Cabinet
Weight (kg)	22.5 Kg 10KVA/KW Electronic Module - Empty of Batteries	
	Battery Configured in Accordance to required Backup Time	
Running Humidity & Temperature	0 ~ 95 % RH (Non-condensing) @ 0~40°C	
Storage Temperature	For UPS 20~70°C; for Batteries -20~30°C	
Protection Class	IP20	
Parallel Operation	Parallel Power Increase up to 2 pcs.	
EPO (Emergency Power Off)	Standard	
Isolation Transformer	Optional	
Noise Level	< 55 dB @ 1 meter	
STANDARDS & CERTIFICATIONS		
Quality	ISO 9001 ; CE	
Compliance	EN50091 (1,2,3); IEC62040 (1,2,3); IEC/EN/AS60950; (IEC/EN/AS60146 series); IEC/EN/ AS61000 series and 60950)	

SY-G reserves the right to change or modify product design, construction, specifications, or materials without prior notice and without incurring any obligation to make such changes and modifications on SY-G products previously or subsequently sold.



MODULAR MAVERICK SERIES

10, 20, 30 KVA / KW

(Hybrid: Power & Battery modules)

THREE PHASE

FEATURES:

- Modular UPS with slots for internal batteries (hybrid)
- True on-line double conversion technology
- High reliability design based on IGBT modules in rectifier & inverter
- Pure sine wave output
- Paralleling option up to 2 units
- High-input power factor: >0.99; Low-input THDi: <3%
- Output power factor: 1
- Hot Swap Plug-In Module
- Strong load adaptability for linear and non-linear loads
- Intelligent module and system protection design
- Low noise generation
- Double DSP (Digital Signal Processor) controller for independent control of each power module, no single-point of failure
- Battery cold start module
- Built-in switch for cabinet input, output and maintenance connection
- Large graphic touch-screen LCD
- Independent charger for batteries
- Intelligent battery management system
- Digital paralleling technology; very low circulation current between modules
- Totally front access, top and bottom cable connections
- Each individual module is configured with independent controller; avoids single-point failure risk
- User-friendly generator interface
- Optional: SNMP card, battery temperature compensation module, parallel kit

BENEFITS:

- Modularity for very flexible service
- High uptime
- High efficiency with energy-saving ECO mode
- Low distortion to utility power
- Extends battery lifespan
- User-friendly and programmable
- Scalability and redundancy
- Higher efficiency, higher frequency modulation and smaller size due to its inverter design
- Ease of installation and maintenance due to its hot swappable feature
- Easy to install even close to other equipment; space-saving footprint in service room

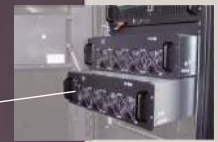

POWER MODULES



BATTERY MODULES

SY-G[®]

Empowering New Frontiers™



INDEX

CATEGORY

www.sy-g.com

TECHNICAL SPECIFICATIONS:
MO SERIES 10-30 KVA (Hybrid)
THREE PHASE



MODEL	MO3P30/3LIH
Phase	Three Phase In / Three Phase Out
Capacity	Grows from 10 to 30 KVA / KW
INPUT	
Input Nominal Voltage	208/220 VAC (line to line)
Input Voltage Range	-40% ~ 20%
Input Power Factor	At Full Load > 0.99
Input Frequency Range	40 - 70 Hz (Selectable)
Rectifier	IGBT
Total Harmonic Distortion (THDi)	< 3%
OUTPUT	
Output Voltage Range	208/220 VAC ± 1 % (at balanced load)
Output Frequency Regulation	50 - 60 Hz (Selectable)
Power Factor	1
Total Harmonic Distortion (THDv)	Linear Load < 1 % ; Non-linear Load < 3 %
Crest Factor (CF)	3:1
Efficiency	95% (ECO Mode 98%)
Transfer Time	Zero
Waveform	Pure Sine Wave
Overload Capacity	At 105% Long time operation, at 110% Load 60 min, 125% Load 10 min, at 150% Load 1 min, >150% 200 ms
BATTERY	
Quantity (12 V DC VRLA)	2 x 10 per string
Type of Battery	Internal battery Modules; 10 Ah
Nominal Voltage	± 120 VDC
Charge Power	0-20% of The Device Power (Selectable)
Back-up time (Full/Half load)	Depending on the configuration of electronic and battery modules
COMMUNICATION & MANAGEMENT	
Communication Ports	RS-232, RS-485, SNMP, EPO, Generator Interface
Compatibility	Supports Windows® 2000/2003/XP/Vista/2008, Windows®7, Linux, Unix, and MAC
Display	Graphic LCD+LED, Touch screen and keyboard
Dry Contacts	Included
GENERAL	
Dimensions UPS Modules & Cabinets (WxDxH) (mm)	600 x 1020 x 2000 Hybrid Cabinet
	440 x 590 x 134 10KVA/KW Electronic Module
Dimensions Battery Modules & Cabinets (WxDxH) (mm)	120 x 824 x 177 Battery Module
	200Kg Hybrid Cabinet
Weight (kg)	22.5 Kg 10KVA/KW Electronic Module - Empty of Batteries
	45 Kg Each Batt Module
Running Humidity & Temperature	0 ~ 95 % RH (Non-condensing) @ 0~40°C
Storage Temperature	For UPS 20~70°C; for Batteries -20~30°C
Protection Class	IP20
Parallel Operation	Parallel Power Increase up to 2 pcs.
EPO (Emergency Power Off)	Standard
Isolation Transformer	Optional
Noise Level	< 55 dB @ 1 meter
STANDARDS & CERTIFICATIONS	
Quality	ISO 9001 ; CE
Compliance	EN50091 (1,2,3); IEC62040 (1,2,3); IEC/EN/AS60950; (IEC/EN/AS60146 series); IEC/EN/ AS61000 series and 60950)

SY-G reserves the right to change or modify product design, construction, specifications, or materials without prior notice and without incurring any obligation to make such changes and modifications on SY-G products previously or subsequently sold.

BATTERIES

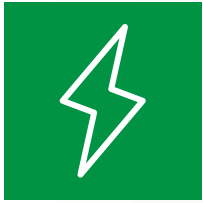

Batteries are mainly used for Uninterruptible Power Supplies (UPS), Electric Power Systems (EPS), emergency back-up power supplies, telecommunications power supplies, DC power systems, and for all other purposes.

Our Portfolio includes two different battery's series:

GENERAL PURPOSE – GP SERIES • 12 V (4 – 250 Ah) • 2 V (65 – 3000 Ah)

LONG LIFE – LL SERIES • 12 V (4.5 – 250 Ah) • 2 V (100 – 3000 Ah)

NOMENCLATURE

Series



Model **GP**

Capacity (V/Ah)

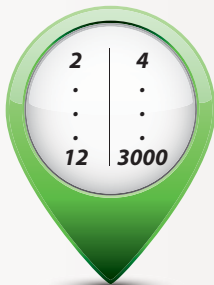

12/7

Internal Code



LG





GENERAL PURPOSE GP SERIES

12 V (4 – 250 Ah)

2 V (65 – 3000 Ah)

FEATURES:

- Uses oxygen recombination technology
- PbCaSn alloy for plate grids
- High-quality AGM separator
- ABS material, which increases the strength of the battery housing
- High-purity raw material
- Silver-coated copper terminals (T1, T2 terminals), brass insert terminals, and lead terminals to improve electric conductivity

BENEFITS:

- Sealed and maintenance-free
- Less gassing and self-discharging
- Extended lifespan; micro short-circuit prevention
- Low self-discharge rate



TECHNICAL SPECIFICATIONS: GP SERIES



MODEL	Nominal Voltage (V)	RATED CAPACITY (Ah)				APPROX DIMENSION								APPROX WEIGHT		TERMINAL TYPE
		20HR	10HR	5HR	1HR	LENGTH		WIDTH		HEIGHT		TOTAL HEIGHT		kg	lbs	
		1.80V/cell	1.80V/cell	1.75V/cell	1.75V/cell	mm	in.	mm	in.	mm	in.	mm	in.			
GP12/4LG	12	4.0	3.72	3.4	2.51	90	3.54	70	2.76	101	3.98	107	4.21	1.45	3.20	T1
GP12/4.5LG	12	4.5	4.19	3.83	2.83	90	3.54	70	2.76	101	3.98	107	4.21	1.48	3.26	T1
GP12/5LG	12	5.0	4.65	4.25	3.14	151	5.94	53	2.09	93	3.66	99	3.9	1.75	3.86	T1
GP12/5.4LG	12	5.4	5	4.6	3.39	90	3.54	70	2.76	101	3.98	107	4.21	1.65	3.64	T1
GP12/6LG	12	5.8	5.51	5.05	3.64	90	3.54	70	2.76	101	3.98	107	4.21	1.88	4.15	T1
GP12/6.5LG	12	6.5	6.05	5.53	4.08	151	5.94	65	2.56	93.5	3.68	99	3.9	2.06	4.54	T1
GP12/7LG	12	7	6.51	5.95	4.4	151	5.94	65	2.56	93.5	3.68	99	3.9	2.18	4.81	T2
GP12/7.2LG	12	7.2	6.7	6.12	4.49	151	5.94	65	2.56	93.5	3.68	99	3.9	2.35	5.18	T2
GP12/7.5LG	12	7.5	6.98	6.38	4.71	151	5.94	65	2.56	93.5	3.68	99	3.9	2.45	5.4	T2
GP12/7.8LG	12	7.8	7.25	6.63	4.9	151	5.94	65	2.56	93.5	3.68	99	3.9	2.50	5.51	T2
GP12/8.5LG	12	8.5	7.91	7.23	5.34	151	5.94	65	2.56	93.5	3.68	99	3.9	2.45	5.40	T2
GP12/8.6LG	12	8.6	7.85	7.0	5.84	151	5.94	65	2.56	93.5	3.68	99	3.9	2.66	5.87	T2
GP12/10LG	12	10	9.3	8.5	6.28	151	5.94	98	3.86	95	3.74	101	3.98	3.25	7.17	T2
GP12/12LG	12	12	11.2	10.2	7.49	151	5.94	98	3.86	95	3.74	101	3.98	3.50	7.72	T2
GP12/14LG	12	14	13	11.9	8.8	151	5.94	98	3.86	95	3.74	101	3.98	4.05	8.93	T2
GP12/15LG	12	15	14	12.8	9.4	181.5	7.15	77	3.03	167.5	6.59	167.5	6.59	4.70	10.4	T3
GP12/18LG	12	18	16.7	15.3	11.2	181.5	7.15	77	3.03	167.5	6.59	167.5	6.59	5.40	11.9	T3
GP12/20LG	12	20	18.6	17	12.6	181.5	7.15	77	3.03	167.5	6.59	167.5	6.59	5.78	12.7	T3
GP12/24LG	12	24	22.3	20.4	15.1	166	6.56	175	6.89	125	4.92	125	4.92	7.20	15.9	T3
GP12/26LG	12	26	24.2	22.1	16.3	166	6.56	175	6.89	125	4.92	125	4.92	7.80	17.2	T12
GP12/28LG	12	28	26	23.8	17.6	166	6.56	175	6.89	125	4.92	125	4.92	8.10	17.9	T3
GP12/30LG	12	30	27.9	25.5	18.8	166	6.56	175	6.89	125	4.92	125	4.92	8.60	19.0	T3
GP12/33LG	12	33	30.7	28.1	20.7	195	7.68	130	5.12	164	6.46	180	7.09	10.5	23.2	T5
GP12/35LG	12	35	32.6	29.8	22	195	7.68	130	5.12	164	6.46	178	7.01	11.2	24.7	T5
GP12/38LG	12	39.5	38	32.7	23.2	197	7.76	165	6.5	170	6.69	170	6.69	12.2	26.9	T6
GP12/40LG	12	40	38.5	33.1	23.5	255	10	97	3.82	203	7.99	203	7.99	12.5	27.6	T7
GP12/45LG	12	46.8	45	38.7	27.5	197	7.76	165	6.5	170	6.69	170	6.69	14.2	31.3	T6
GP12/50LG	12	52	50	43	30.5	257	10.1	132	5.2	200	7.87	200	7.87	16.0	35.3	T6
GP12/55LG	12	57.2	55	47.3	33.6	229	9.02	138	5.43	205	8.07	226	8.9	16.5	36.4	T6
GP12/60LG	12	62.4	60	51.6	36.6	259	10.2	168	6.61	208	8.19	214	8.43	18.5	40.8	T6
GP12/65LG	12	65	62.5	53.8	38.1	348	13.7	167	6.57	178	7.01	178	7.01	19.2	42.3	T6
GP12/70LG	12	72.8	70	60.2	42.7	348	13.7	167	6.57	178	7.01	178	7.01	21.6	47.6	T6
GP12/75LG	12	78	75	64.5	45.8	259	10.2	168	6.61	208	8.19	214	8.43	22.3	49.2	T6
GP12/80LG	12	83.2	80	68.8	48.8	259	10.2	168	6.61	208	8.19	214	8.43	24	52.9	T6
GP12/90LG	12	93.6	90	77.4	54.9	330	13	173	6.81	212	8.35	220	8.66	28	61.7	T11
GP12/100LG	12	104	100	86	61	330	13	173	6.81	212	8.35	220	8.66	30.4	67	T11
GP12/120LG	12	124.8	120	103.2	73.2	410	16.1	177	6.97	225	8.86	225	8.86	35	77.2	T11
GP12/135LG	12	140.4	135	116.1	82.4	345	13.6	172	6.77	274	10.8	280	11	41.2	90.8	T11
GP12/150LG	12	156	150	129	91.5	485	19.1	170	6.69	240	9.45	240	9.45	43.5	95.9	T11
GP12/180LG	12	187.2	180	154.8	109.8	530	20.9	209	8.2	214	8.43	220	8.66	52.8	116.4	T11
GP12/200LG	12	208	200	172	122	522	20.6	240	9.45	218	8.58	224	8.82	60.2	132.7	T11
GP12/250LG	12	260	250	215	152.5	522	20.6	268	10.6	220	8.66	226	8.9	73	161	T11
GP2/65LG	2	68.3	65	55.6	39	170	6.69	72	2.83	205	8.07	212	8.35	4.7	10.4	T6
GP2/72LG	2	75.6	72	61.6	43.2	170	6.69	72	2.83	205	8.07	212	8.35	5.5	12.1	T6
GP2/100LG	2	105	100	85.5	60	170	6.69	72	2.83	205	8.07	212	8.35	6	13.2	T6
GP2/120LG	2	126	120	103	72	170	6.69	98	3.86	205	8.07	212	8.35	7.6	16.8	T7
GP2/150LG	2	157.5	150	128	90	170	6.69	98	3.86	205	8.07	212	8.35	8.5	18.7	T7
GP2/200LG	2	210	200	171	120	170	6.69	110	4.33	328	12.9	350	13.8	12.7	28	T11
GP2/250LG	2	262.5	250	214	150	170	6.69	110	4.33	328	12.9	350	13.8	13.8	30.4	T11
GP2/300LG	2	315	300	257	180	170	6.69	150	5.91	328	12.9	350	13.8	17.7	39	T11
GP2/350LG	2	367.5	350	299	210	170	6.69	150	5.91	328	12.9	350	13.8	19.3	42.6	T11
GP2/400LG	2	420	400	342	240	210	8.27	175	6.89	330	13	350	13.8	24.3	53.6	T11
GP2/450LG	2	472.5	450	385	270	210	8.27	175	6.89	330	13	350	13.8	27	59.5	T11
GP2/500LG	2	525	500	428	300	240	9.45	175	6.89	330	13	350	13.8	29	63.9	T11
GP2/600LG	2	630	600	513	360	300	11.8	175	6.89	330	13	350	13.8	35.7	78.7	T11
GP2/800LG	2	840	800	684	480	410	16.1	175	6.89	330	13	350	13.8	47	103.6	T11
GP2/1000LG	2	1050	1000	855	600	475	18.7	175	6.89	328	12.9	350	13.8	59	130.1	T11
GP2/1200LG	2	1260	1200	1026	720	475	18.7	175	6.89	328	12.9	350	13.8	66.4	146.4	T11
GP2/1500LG	2	1575	1500	1283	900	403	15.9	354	13.9	339	13.3	349	13.7	96	211.7	T11
GP2/2000LG	2	2100	2000	1710	1200	490	19.3	350	13.8	339	13.3	349	13.7	120.5	265.7	T11
GP2/2500LG	2	2625	2500	2138	1500	490	19.3	350	13.8	339	13.3	349	13.7	133.6	294.6	T11
GP2/3000LG	2	3150	3000	2565	1800	709	27.9	350	13.8	337	13.3	347	13.66	180	396.9	T11

(1) — Certifications & Standards: ISO 9001 ; ISO 14001 ; UL ; CE ; IEC

SY-G reserves the right to change or modify product design, construction, specifications, or materials without prior notice and without incurring any obligation to make such changes and modifications on SY-G products previously or subsequently sold.



LONG LIFE LL SERIES

12 V (4.5 – 250 Ah)

2 V (100 – 3000 Ah)

FEATURES:

- Uses oxygen recombination technology
- Special grid alloy and high-purity raw material
- ABS material, which increases the strength of battery housing
- Grid refining technology and thicker plates
- Lower acid density, excess of electrolyte, and large distance between plates
- Unique vent-valve design

BENEFITS:

- Sealed and maintenance-free
- Less gassing and self-discharging
- Extended battery-standby life and reduced corrosion speed
- Water loss control
- Air and spark prevention ingress valve



SY-G[®]

Empowering New Frontiers™



INDEX

CATEGORY

www.sy-g.com

**TECHNICAL SPECIFICATIONS:
LL SERIES**



MODEL	Nominal Voltage (V)	RATED CAPACITY (Ah)				APPROX DIMENSION								APPROX WEIGHT		TERMINAL TYPE
		20HR		10HR		LENGTH		WIDTH		HEIGHT		TOTAL HEIGHT		kg	lbs	
		1.80V/cell	1.80V/cell	1.75V/cell	1.75V/cell	mm	in.	mm	in.	mm	in.	mm	in.			
LL12/4.5LL	12	4.77	4.5	3.9	2.77	151	5.94	53	2.09	93	3.66	99	3.9	1.9	4.19	T1
LL12/7LL	12	7.42	7	6.07	4.31	151	5.94	65	2.56	93.5	3.68	99	3.9	2.45	5.4	T2
LL12/12LL	12	12.7	12	10.4	7.38	151	5.94	98	3.86	95	3.74	101	3.98	3.8	8.38	T2
LL12/18LL	12	19.1	18	15.6	11.1	181.5	7.15	77	3.03	167.5	6.59	167.5	6.59	5.7	12.6	T3
LL12/24LL	12	25.4	24	20.8	14.8	166	6.54	175	6.89	125	4.92	125	4.92	7.8	17.2	T3
LL12/26LL	12	27.6	26	22.6	16	166	6.54	175	6.89	125	4.92	125	4.92	8.4	18.5	T3
LL12/28LL	12	29.7	28	24.3	17.2	166	6.54	175	6.89	125	4.92	125	4.92	8.8	19.4	T3
LL12/38LL	12	40.6	38	33.1	23.6	197	7.76	165	6.5	170	6.69	170	6.69	13.2	29.1	T6
LL12/45LL	12	45	42	36.6	26	197	7.76	165	6.5	170	6.69	170	6.69	14.5	32	T6
LL12/55LL	12	58.9	55	47.9	34.1	228	8.98	137	5.39	210	8.27	230	9.06	17.7	39	T6/T9
LL12/60LL	12	64.2	60	52.2	37.2	260	10.2	168	6.61	210	8.27	216	8.5	21	46.3	T6
LL12/65LL	12	69.6	65	56.6	40.3	348	13.7	167	6.57	178	7.01	178	7.01	21.3	47	T6
LL12/70LL	12	74.9	70	60.9	43.4	348	13.7	167	6.57	178	7.01	178	7.01	24	52.9	T6
LL12/75LL	12	80.3	75	65.3	46.5	259	10.2	168	6.61	208	8.19	230	9.06	23	50.7	T6
LL12/90LL	12	96.3	90	78.3	55.8	305	12	168	6.61	207	8.15	213	8.39	27.5	60.6	T6
LL12/100LL	12	107	100	87	62	330	13	173	6.81	212	8.35	220	8.66	31.5	69.5	T11
LL12/120LL	12	128.4	120	104.4	74.4	410	16.1	177	6.97	225	8.86	225	8.86	37.6	82.9	T11
LL12/140LL	12	149.8	140	122	86.8	345	13.6	172	6.77	274	10.8	280	11	45.5	100.3	T11
LL12/150LL	12	160.5	150	130.5	93	485	19.1	170	6.69	240	9.45	240	9.45	48.2	106.3	T11
LL12/200LL	12	214	200	174	124	522	20.6	240	9.45	218	8.58	224	8.82	64	141.1	T11
LL12/250LL	12	267.5	250	217.5	155	522	20.6	268	10.55	220	8.66	226	8.9	77	169.8	T11
LL2/100LL	2	107	100	87	62	170	6.69	72	2.83	205	8.07	212	8.35	6	13.2	T6
LL2/150LL	2	160.5	150	130.5	93	170	6.69	98	3.86	205	8.07	212	8.35	8.5	18.7	T7
LL2/200LL	2	214	200	174	124	170	6.69	110	4.33	328	12.9	350	13.8	13.6	30	T11
LL2/250LL	2	267.5	250	217.5	155	170	6.69	110	4.33	328	12.9	350	13.8	14.5	32	T11
LL2/300LL	2	321	300	261	186	170	6.69	150	5.91	328	12.9	350	13.8	18.7	41.2	T11
LL2/350LL	2	374.5	350	304.5	217	170	6.69	150	5.91	328	12.9	350	13.8	20.5	45.2	T11
LL2/400LL	2	428	400	348	248	210	8.27	175	6.89	330	13	350	13.8	25.5	56.23	T11
LL2/450LL	2	481.5	450	392	279	210	8.27	175	6.89	330	13	350	13.8	26.3	57.99	T11
LL2/500LL	2	535	500	435	310	240	9.45	175	6.89	330	13	350	13.8	30.5	67.2	T11
LL2/600LL	2	642	600	522	372	300	11.8	175	6.89	330	13	350	13.8	38.2	84.2	T11
LL2/800LL	2	856	800	696	496	410	16.1	175	6.89	330	13	350	13.8	51.5	113.6	T11
LL2/1000LL	2	1070	1000	870	620	475	18.7	175	6.89	328	12.9	350	13.8	60	132.3	T11
LL2/1200LL	2	1284	1200	1044	744	475	18.7	175	6.89	328	12.9	350	13.8	65.8	145.1	T11
LL2/1500LL	2	1605	1500	1305	930	403	15.9	354	13.94	339	13.3	349	13.7	98	216.1	T11
LL2/2000LL	2	2140	2000	1740	1240	490	19.3	350	13.78	339	13.3	349	13.7	125	275.6	T11
LL2/2500LL	2	2675	2500	2175	1550	490	19.3	350	13.78	339	13.3	349	13.7	138	304.3	T11
LL2/3000LL	2	3210	3000	2610	1860	709	27.9	350	13.78	337	13.3	347	13.66	188	414.5	T11

(1) — Certifications & Standards: ISO 9001 ; ISO 14001 ; UL ; CE ; IEC

SY-G reserves the right to change or modify product design, construction, specifications, or materials without prior notice and without incurring any obligation to make such changes and modifications on SY-G products previously or subsequently sold.



COOLING SOLUTIONS

SY-G[®]

Empowering New Frontiers™

High-efficiency cooling solutions engineered for continuous 24/7/365 operation, keeping sensitive equipment at an appropriate temperature and humidity range. These innovative solutions are designed to satisfy the changing expectations and requirements of different industries.



INDEX

CATEGORY

MISSION-CRITICAL AIR CONDITIONER SYSTEMS

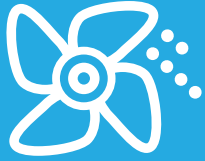

Air conditioners designed for mission-critical applications, providing temperature and humidity control, high reliability, high stability, and better energy saving performance. All units are built for 24/7/365 continuous operation.

Our Portfolio includes three different air-conditioners series:

PERIMETRAL PRECISION AIR CONDITIONERS SERIES 10 – 140 KW

WALL-FIT PRECISION AIR CONDITIONERS SERIES 10 – 13 KW

INROW PRECISION AIR CONDITIONERS – SERIES 24 & 38 KW

PACKAGED AIR CONDITIONERS SERIES 3 - 18 KW

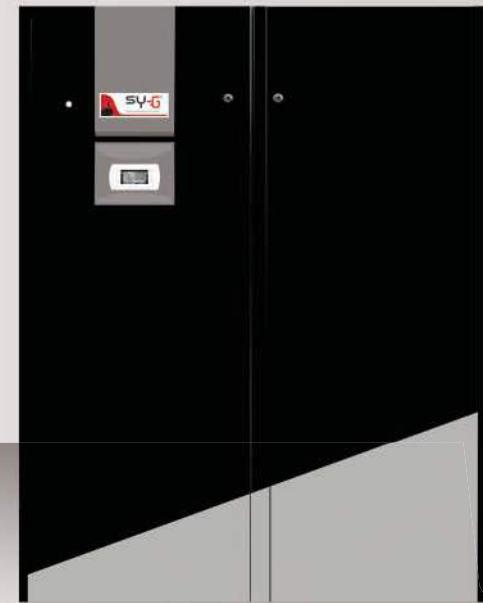
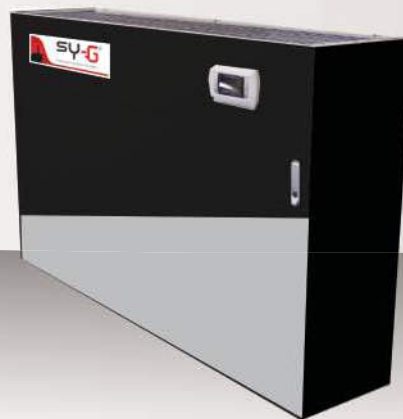

SY-G[®]

Empowering New Frontiers™



INDEX

CATEGORY

www.sy-g.com

DESCRIPTION OF FEATURES

1. Nomenclature

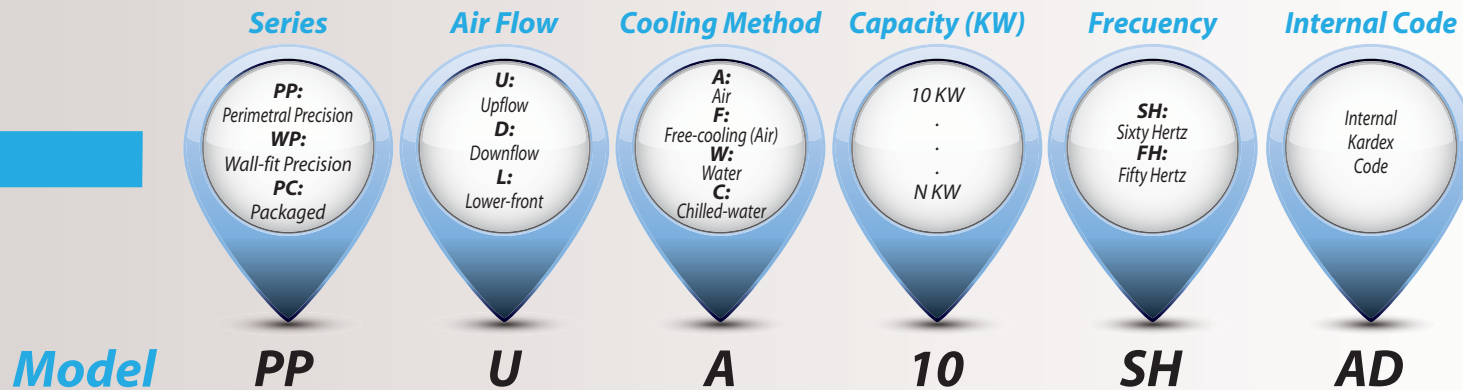

2. AC directly coupled fan

- Backwards curved, directly coupled, carbon-filter fan
- Lifespan of 10 to 15 years
- 35% more efficient because of its inclination and direct coupling
- Maintenance-free ball bearings
- No belts and pulleys
- Does not require belt changes and/or pulley adjustments
- High efficiency
- Quiet operation
- High strength, corrosion-resistant aluminum alloy carrier with special, fiber-reinforced plastic jacket
- Thermal overload motor protection

3. Microprocessor

- All components are connected to the microprocessor and are continuously monitored and controlled, and to avoid malfunction, the unit is shut down and the failure alarm is shown on the display.
- All units are built with Carel's most recent pCO microprocessor with automatic control and monitoring capabilities.
- All the pCO series controllers feature a 16-bit microprocessor, 2 MB flash memory, and a large LCD display.
- The control system has an adjustable tolerance temperature of +/- 0.1°C and a relative tolerance humidity control of +/- 0.1% RH.
- The pCO series controllers can interface with various communication protocols like ModBus, BacNet, Johnson, Metasys, DLL for Windows, TCP/IP, SNMP, LonWorks and Trend.
- The pCO series control system allows for configuration and display in several languages, including: English, Spanish, Chinese, Japanese, etc.
- Multiple levels of password protection for parameter configuration.
- Up to sixteen (16) units can be installed to function synchronously in parallel or in a redundant configuration.
- Lead-lag control so that when two or more units are installed, and in case of a unit failure, the standby unit will activate automatically.
- Allows setting daily starts and stops of the unit according to weekly program.
- Dry contacts inputs and outputs.

DESCRIPTION OF FEATURES

4. Refrigeration system + independent charging system

Refrigeration system includes external thermostatic expansion valve, liquid and humidity indicator, dry filter, high/low pressure switch set on suction pipe, high-pressure sensor set on exhaust pipe, and designed to operate with environmentally-friendly refrigerant.

5. Indoor/ outdoor service valve

A valve installed in the indoor and outdoor units to trap the refrigerant in order to perform maintenance or repairs in the copper piping network.

6. High Sensible Heat Ratio (SHR)

The Sensible Heat Ratio (SHR) is the relation between sensible heat load (dry heat produced primarily by electronic equipment) and total heat load, which in turn, is the sum of sensible heat load and latent heat load (humid heat produced primarily by living beings). Mission-critical environments require a precision cooling system that provides a high SHR specification that removes primarily the sensible heat generated, and consequently guarantees a precise humidity control to avoiding electrostatic discharges.

7. Energy Efficiency Ratio (EER)

Is the ratio between the net cooling capacity in BTU per hour to the total input rate of electric power applied in Watts.

8. Operational altitude above sea level

For PP Series, all systems are designed and manufactured to operate at 3,000 meters above sea level without suffering any degradation. This is an optional feature for WP Series and PC Series.

9. Aluminum-built outdoor unit

For PP Series, all Outdoor units are manufactured in aluminum in order to prevent corrosion from humidity and salinity, and their lightness allows for versatile installation, either horizontally or vertically. Aluminum construction of Outdoor units is optional for WP Series.

10. Parallel, redundant and alternating operation

Up to sixteen units can be connected in parallel for capacity growth and/or for redundancy.

- Capacity Growth: The units can be connected in parallel to increase total capacity of the system.
- Redundancy: All units in this system share the cooling load. If one fails, or is under maintenance, the remaining units continue supporting the cooling load without interruption.
- Alternation: The units can be configured to operate in shifts so as to assure that all units have similar operating hours.

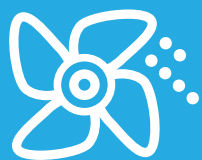

PERIMETRAL PRECISION AIR CONDITIONERS

CHAMPION

10 - 30 KW

INDOOR UNIT - STANDARD FEATURES

- Constructed with a steel frame and painted with epoxy powder to ensure proper adhesion to the surface
- Microprocessor control system with LCD display
- Equipped with AC directly-coupled centrifugal fan (no belts and pulleys)
- Aluminum water pan with drainpipe, liquid receiver complete with accessories, leak detection sensor, and coolant tank
- R407C environmentally-friendly refrigerant
- Electric resistance heaters with temperature control, built with low density heating components and non-corrosive metal sheath tubular finned
- Self-contained immersed electrode boiler type humidifier with water level control and auto-drain functions
- Independent electrical protections for: compressor, fan, motor, heater, and humidifier
- Hermetic scroll compressor equipped with: electrical protector, phase protector, exhaust muffler, and oil tank heater
- Thermodynamic expansion valve (TXV)
- Washable G4 fiber-pad folded filter, built with an exterior aluminum mount structure
- Hot gas bypass
- Liquid detection sensor
- Independent refrigerant charging system for high and low pressure lines
- Indoor service valves

OPTIONAL FEATURES

- Electronically Commuted (EC) fan
- Electronic expansion valve (EXV)
- Touch screen display for controller
- Multiple communication protocols for remote monitoring, such as: SNMP (web interface), Modbus and BACnet.

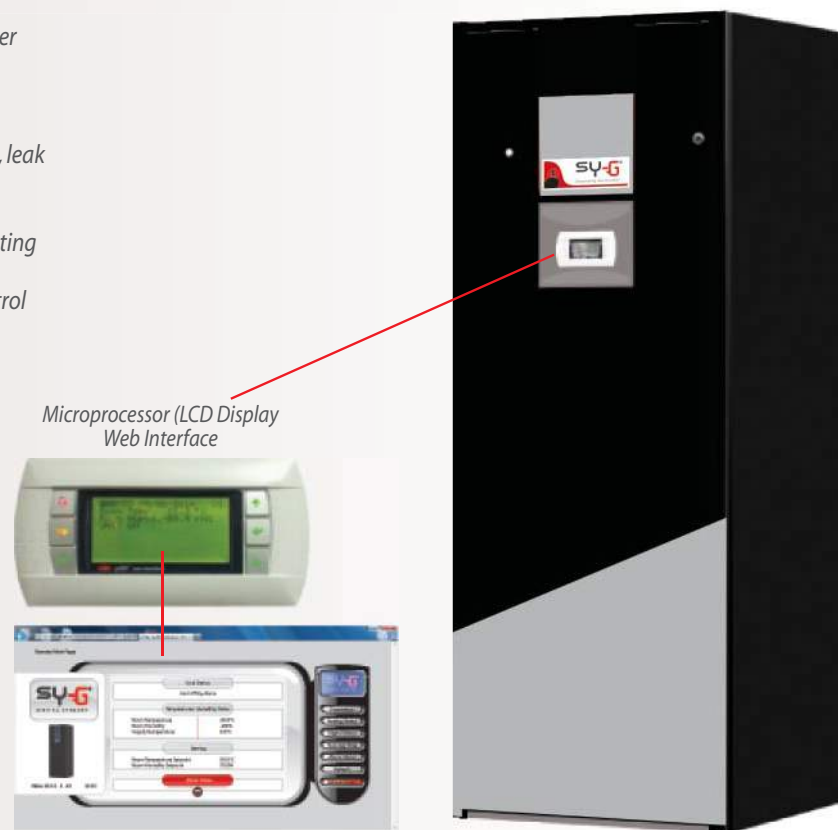

Microprocessor (LCD Display
Web Interface)



CHAMPION SERIES INDOOR UNIT

BENEFITS:

- Capability for cooling, heating, de-humidifying, and humidifying, as well as filtering air in the room
- Provides high Sensible Heat Ratio (SHR) and world-class Energy Efficiency Ratio (EER)
- Designed and manufactured to operate at 3,000 meters above sea level without suffering any degradation
- Random multiple units insertion after a power failure, with a time delay from 2 to 60 seconds, avoiding simultaneous starting of the units
- The control system allows customized programming of temperature, relative humidity, and manual start-up of components. In addition, up to sixteen (16) units can be installed to function synchronously in parallel, alternating, and/or in redundant configurations
- Optional energy saving working mode
- AC directly-coupled centrifugal fans are 35% more efficient, have an average lifespan of 10 to 15 years, and for ease of maintenance, there are no belts to change or pulleys to adjust
- Compressor positive start to avoid short-cycling alarms and low-pressure lockout
- Highly accurate temperature and humidity control that extends the service interval and life-cycle, designed to operate with ordinary tap water and equipped with automatic water supply and flushing system to reduce mineral precipitation
- All units are 100% front serviceable with all major components located away from the airflow stream, providing important space savings
- Electric board, protection switches and control devices are installed in a separated compartment, making the unit serviceable without requiring shut down

1.- Centrifugal Fan

2.- Washable G4 Filter

3.- Hot Gas Bypass

4.- Maintenance Valve

5.- Frontal Maintenance

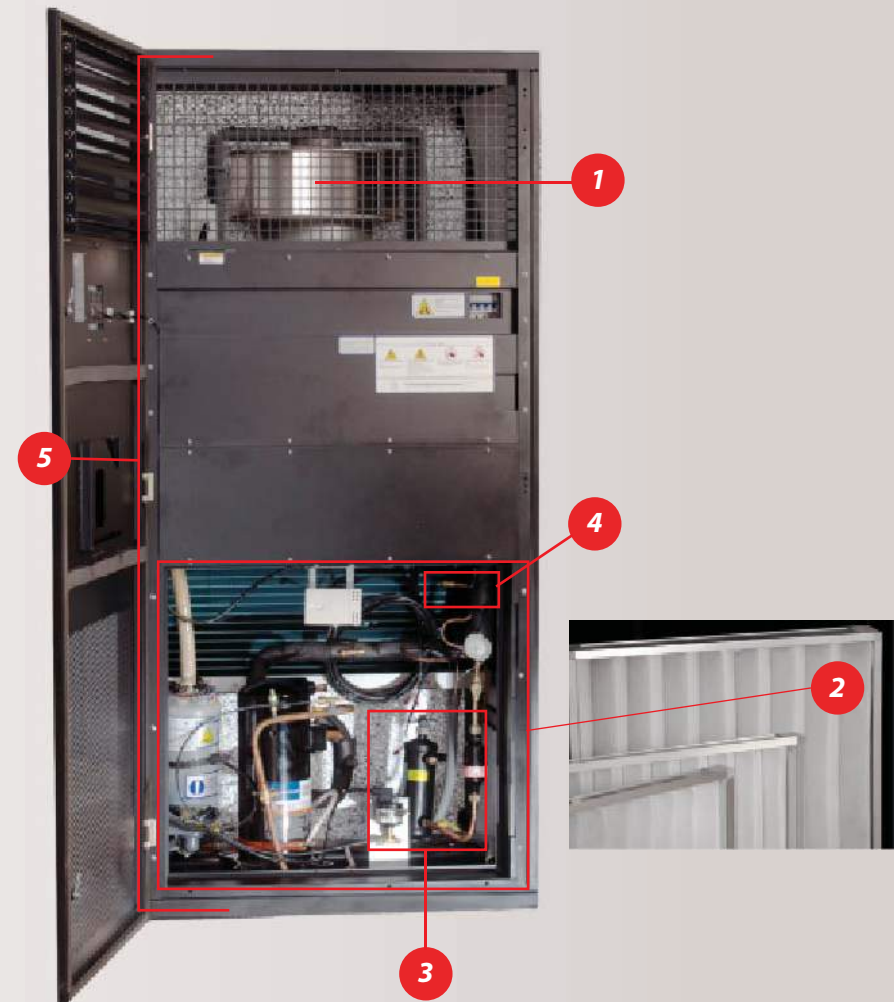

**TECHNICAL SPECIFICATIONS:
INDOOR UNIT FOR CHAMPION
DXA⁽¹⁾ 10 KW TO 30 KW**



UNIT MODEL	PPUA10SL1PAD	PPUA15SL3PAD	PPUA18SL3PAD	PPUA22SL3PAD	PPUA25SL3PAD	PPUA30SL3PAD	
	PPDA10SL1PAD	PPDA15SL3PAD	PPDA18SL3PAD	PPDA22SL3PAD	PPDA25SL3PAD	PPDA30SL3PAD	
	PPLA10SL1PAD	PPLA15SL3PAD	PPLA18SL3PAD	PPLA22SL3PAD	PPLA25SL3PAD	PPLA30SL3PAD	
Supply air scheme ⁽²⁾	U: Upflow		D: Downflow	L: Lower front discharge			
POWER SUPPLY							
Power source	208 - 230V, 1Ph, 60Hz		208 - 230V, 3Ph, 60Hz				
COOLING CAPACITY ⁽³⁾							
Total capacity	KW [Btu/h]	10.2 [34,803]	15.6 [53,229]	18.4 [62,783]	23.6 [80,526]	26.0 [88,715]	30.5 [104,070]
Sensible capacity	KW [Btu/h]	9.2 [31,391]	14.0 [47,769]	16.6 [56,641]	21.2 [72,327]	23.4 [79,844]	26.5 [90,421]
SUPPLY FAN							
Type	Plug - in AC centrifugal fan						
Qty of fan	n	1					
Air Volume	m3/h [CFM]	2,500 [1,471]	4,050 [2,383]	5,600 [3,296]	7,300 [4,296]		
COMPRESSOR							
Type	Hermetic scroll						
Qty of Compressor	1						
REFRIGERANT							
Type	R407C						
Control	Thermal expansion valve						
Charge weight	Kg	4,2	5,0	6,4	8,0	10,0	11,0
FILTERS							
Type	G4						
Qty of filters	n	1			2		
ELECTRIC HEATER							
Type	Stainless steel tube						
Working class	n.	1	2				
Heating capacity ⁽⁴⁾	KW	4,5	6,0	9,0			
HUMIDIFIER							
Type	Electrode						
Humidifying capacity ⁽⁴⁾	Kg/h	3	5	8			
DIMENSIONS AND WEIGHT							
Width	mm	580	900	1.300			
Depth	mm	650	750	750			
Height	mm	1.910	1.910	1.910			
Weight	Kg	142	255	290	370	460	490
OUTDOOR UNIT							
Model ⁽⁵⁾	OPCMD4SLA		OPCME5SLA	OPCME8SLA	OPCME10SLA		
Qty	n.	1					
CERTIFICATIONS & STANDARDS							
Quality	ISO 9001:2008 ; ISO 14001:2004 ; ISO 13485:2003 ; OHSAS 18001:2007						
Compliance	CE, CQC31-439125-2010						

(1) — DXA: Direct expansion cooled with air

(2) — All specifications apply for U: Upflow, D: Downflow and L: Lower front discharge.

(3) — Return air dry bulb temperature 24 °C, RH 50 %, Outdoor dry bulb temperature 35 °C.

(4) — The above capacities of heater and humidifier are standard. Other customized option are available

(5) — For technical specifications of outdoor unit, please refer to the next table: Outdoor Unit Technical Specifications for: PP Series DXA 10 KW to 30 KW at 50/60 Hz
SY-G reserves the right to change or modify product design, construction, specifications, or materials without prior notice and without incurring any obligation to make such changes and modifications on SY-G products previously or subsequently sold.





OUTDOOR UNIT FEATURES

- Remote aluminum built air-cooled condenser with axial fan (DXA)
- Built entirely in heavy gauge corrosion resistant aluminum
- Aluminum fins and copper tubes staggered in direction of the airflow
- Fan speed is step-less controlled by microprocessor according to compressor discharge pressure
- Outdoor service valves

BENEFITS:

- Designed and manufactured to operate at 3,000 meters above sea level without suffering any degradation
- Can be installed in either vertical or horizontal air discharge, for footprint considerations
- Fan motor provides steady operation, lower noise level, energy savings and low temperature start-up

TECHNICAL SPECIFICATIONS: OUTDOOR UNIT FOR CHAMPION SERIES DXA⁽¹⁾ 10 KW TO 30 KW

MODEL		OPCMD4SLA	OPCME5SLA	OPCME8SLA	OPCME10SLA
Qty of fan		1			
Power input	KW	0,28	0,37	0,63	
Current	A	1,3	1,7	3	
Gas pipe	∅	5/8"	3/4"	7/8"	
Liquid pipe	∅	1/2"		5/8"	
Length	mm	808	1.140	1.340	
Width	mm	509	475	620	
Height	mm	789	770	1.070	
Weight	Kg	35	47	95	110

(1) — DXA: Direct expansion cooled with air

(2) — The capacity is rated at entering air temperature 35° C and condensing temperature 50° C condition
 (3) — The noise is measured at 1 meter distance from unit at open field on condenser coil side according to ISO 3744

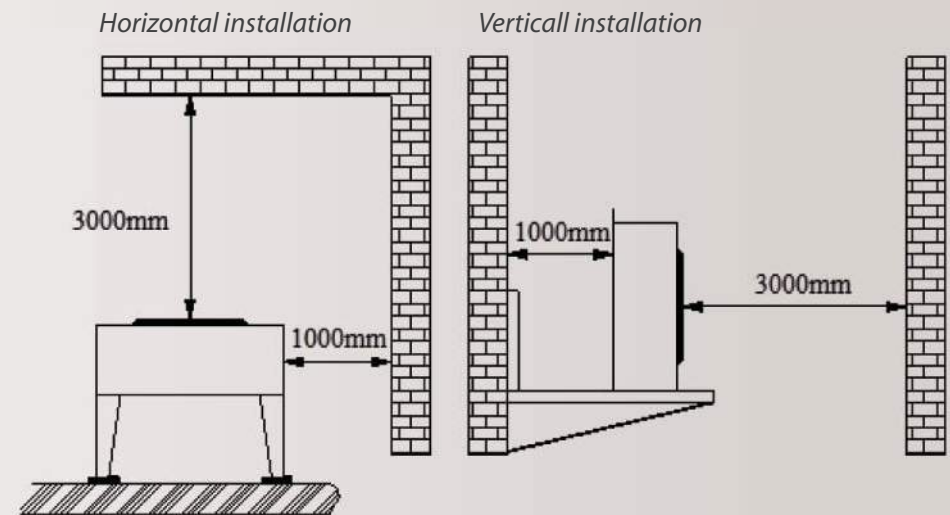

PERIMETRAL PRECISION AIR CONDITIONERS

EMPEROR SERIES

35 – 100 KW

INDOOR UNIT - STANDARD FEATURES

- Constructed with a steel frame and painted with epoxy powder to ensure proper adhesion to the surface
- Microprocessor control system with LCD display
- Equipped with AC directly-coupled centrifugal fan (no belts and pulleys)
- Aluminum water pan with drainpipe, liquid receiver complete with accessories, leak detection sensor, and coolant tank
- R407C environmentally-friendly refrigerant
- Electric resistance heaters with temperature control, built with low density heating components and non-corrosive metal sheath tubular finned
- Self-contained immersed electrode boiler type humidifier with water level control and auto-drain functions
- Independent electrical protections for: compressor, fan, motor, heater, and humidifier
- Hermetic scroll compressor equipped with: electrical protector, phase protector, exhaust muffler, and oil tank heater
- Thermodynamic expansion valve (TXV)
- Washable G4 fiber-pad folded filter, built with an exterior aluminum mount structure
- Hot gas bypass
- Liquid detection sensor
- Independent refrigerant charging system for high and low pressure lines
- Indoor service valves

OPTIONAL FEATURES

- Electronically Commuted (EC) fan
- Electronic expansion valve (EXV)
- Touch screen display for controller
- Multiple communication protocols for remote monitoring, such as: SNMP (web interface), Modbus and BACnet.

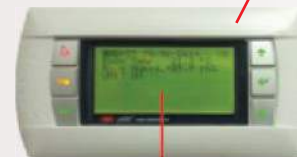

STANDARD FEATURES EMPEROR SERIES 35-100 KW

BENEFITS:

- Capability for cooling, heating, de-humidifying, and humidifying, as well as filtering air in the room
- Provides high Sensible Heat Ratio (SHR) and world-class Energy Efficiency Ratio (EER)
- Designed and manufactured to operate at 3,000 meters above sea level without suffering any degradation
- Random multiple units insertion after a power failure, with a time delay from 2 to 60 seconds, avoiding simultaneous starting of the units
- The control system allows customized programming of temperature, relative humidity, and manual start-up of components. In addition, up to sixteen (16) units can be installed to function synchronously in parallel, alternating, and/or in redundant configurations
- Optional energy saving working mode
- AC directly-coupled centrifugal fans are 35% more efficient, have an average lifespan of 10 to 15 years, and for ease of maintenance, there are no belts to change or pulleys to adjust
- Compressor positive start to avoid short-cycling alarms and low-pressure lockout
- Highly accurate temperature and humidity control that extends the service interval and life-cycle, designed to operate with ordinary tap water and equipped with automatic water supply and flushing system to reduce mineral precipitation
- All units are 100% front serviceable with all major components located away from the airflow stream, providing important space savings
- Electric board, protection switches and control devices are installed in a separated compartment, making the unit serviceable without requiring shut down

1.- Centrifugal Fans

2.- Washable G4 Filter

3.- Hot Gas Bypass

4.-Maintenance Valves

5.- Frontal Maintenance

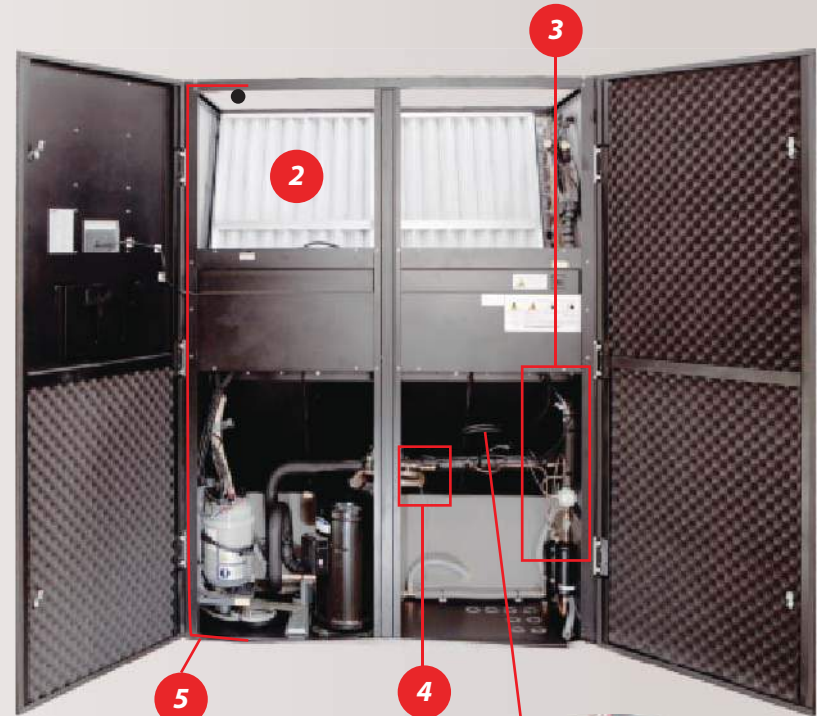

**TECHNICAL SPECIFICATIONS:
INDOOR UNIT FOR EMPEROR
SERIES DXA⁽¹⁾ 35 KW TO 100 KW**



UNIT MODEL	PPUA35SL3PAO	PPUA40SL3PAO	PPUA50SL3PAO	PPUA60SL3PAO	PPUA70SL3PAO	PPUA80SL3PAO	PPUA90SL3PAO	PPUA100SL3PAO	
	PPDA35SL3PAO	PPDA40SL3PAO	PPDA50SL3PAO	PPDA60SL3PAO	PPDA70SL3PAO	PPDA80SL3PAO	PPDA90SL3PAO	PPDA100SL3PAO	
Supply air scheme ⁽²⁾	U: Upflow				D: Downflow				
POWER SUPPLY									
Power source	208V, 3Ph, 60Hz								
COOLING CAPACITY ⁽³⁾									
Total	KW [Btu/h]	35.3 [120,448]	41.8 [142,627]	50.5 [172,313]	60.2 [205,410]	70.6 [240,897]	80.2 [273,653]	85.3 [291,055]	97.6 [333,025]
Sensible	KW [Btu/h]	33.5 [114,320]	38.9 [132,643]	47.0 [160,456]	57.8 [197,194]	66.2 [225,820]	74.0 [252,356]	79.6 [271,606]	90.3 [308,048]
SUPPLY FAN									
Type	Plug - in AC centrifugal fan								
Qty of fan	n	1	2		3				
Air volume	m3/h [CFM]	9,600 [5,650]	12,600 [7,416]	13,600 [8,004]	17,800 [10,476]	19,200 [11,300]	21,000 [12,360]	24,600 [14,479]	27,900 [16,421]
COMPRESSOR									
Type	Hermetic scroll compressor								
Qty of Compressor	n	1	2						
REFRIGERANT									
Type	R407C								
Control	Thermal expansion valve								
Charge weight	Kg	12	15	2×10	2×11	2×12	2×15	2×17	2×18
FILTERS									
Type	G4								
Qty of filters - U: Upflow	n	2			3			4	
Qty of filters - D: Downflow	n	4	6				8		
ELECTRIC HEATER									
Type	Stainless steel								
Working class	n	2							
Heating capacity ⁽⁴⁾	KW	9	13,5			18			
HUMIDIFIER									
Type	Electrode								
Humidifying capacity ⁽⁴⁾	Kg/h	5	8						
DIMENSIONS AND WEIGHT									
Length	mm	1.480	1.750		2.490			3.095	
Depth	mm	890	890			890			
Height	mm	1.960	1.960		1.960			2.050	
Weight	Kg	420	630	680	940	980	1.040	1.230	1.270
OUTDOOR UNIT									
Model ⁽⁵⁾		OPCME15SLA	OPCME8SLA	OPCME10SLA		OPCME15SLA		OPCME20SLA	
Qty condenser	n	1	2						
CERTIFICATIONS & STANDARDS									
Quality	ISO 9001:2008 ; ISO 14001:2004 ; ISO 13485:2003 ; OHSAS 18001:2007								
Compliance ⁽⁶⁾	CE ; CQC31-439125-2010								

(1) – DXA: Direct expansion cooled with air

(2) – All specifications apply for U: Upflow and D: Downflow discharge.

(3) – Return air dry bulb temperature 24 °C, RH 50 %, Outdoor dry bulb temperature 35 °C

(4) – The above capacities of heater and humidifier are standard. Other customized option are available

(5) – For technical specifications of outdoor unit, please refer to the next table: Outdoor Unit Technical Specifications for: PP Series DXA 35 KW to 100 KW at 50/60 Hz

(6) – CQC31-439125-2010 Energy saving standard apply only to 40, 60, 70, 80 KW models

SY-G reserves the right to change or modify product design, construction, specifications, or materials without prior notice and without incurring any obligation to make such changes and modifications on SY-G products previously or subsequently sold.



**TECHNICAL SPECIFICATIONS:
INDOOR UNIT FOR EMPEROR SERIES
FC DXA⁽¹⁾ 35 KW TO 100 KW**



UNIT MODEL	PPUF35SHAO	PPUF40SHAO	PPUF50SHAO	PPUF60SHAO	PPUF70SHAO	PPUF80SHAO	PPUF90SHAO	PPUF100SHAO	
	PPDF35SHAO	PPDF40SHAO	PPDF50SHAO	PPDF60SHAO	PPDF70SHAO	PPDF80SHAO	PPDF90SHAO	PPDF100SHAO	
Supply air scheme ⁽²⁾	U: Upflow D: Downflow								
POWER SUPPLY									
Power source	208V, 3Ph, 60Hz								
COMPRESSOR COOLING CAPACITY⁽³⁾									
Total	KW [Btu/h]	35.9 [122,495]	43.5 [148,428]	51.2 [174,701]	61.3 [209,164]	71.1 [242,603]	81.2 [277,065]	86.1 [293,785]	101.3 [345,649]
Sensible	KW [Btu/h]	33.7 [114,989]	41.3 [140,921]	47.5 [162,076]	56.2 [191,762]	68.2 [232,708]	76.2 [260,005]	81.7 [278,772]	95.8 [326,883]
FREE COOLING CAPACITY⁽⁴⁾									
Total	KW [Btu/h]	32.3 [110,212]	39.2 [133,755]	46.1 [157,299]	55.2 [188,350]	64.0 [218,377]	73.1 [249,427]	77.5 [264,427]	91.2 [311,187]
Sensible	KW [Btu/h]	30.3 [103,387]	37.2 [126,931]	42.7 [145,698]	50.6 [172,654]	61.4 [209,505]	68.6 [234,072]	73.6 [251,133]	86.2 [294,126]
FAN									
Qty of fan	n	1	2						
Air volume	m3/h [CFM]	9,600 [5,650]	12,600 [7,416]	13,600 [8,005]	17,800 [10,477]	19,200 [11,301]	21,000 [12,360]	24,600 [14,479]	27,900 [16,421]
COMPRESSOR									
Qty of compressor	n	1	2						
REFRIGERANT									
Type	R407C								
FILTERS									
Type	G4								
ELECTRIC HEATER									
Heating capacity ⁽⁵⁾	KW	9.0	13.5	18.0					
HUMIDIFIER									
Humidifying capacity ⁽⁵⁾	Kg/h	5.0	8.0				15.0		
FREE COOLING									
Water flow	m3/h	5.6	6.7	7.9	9.5	11	12.6	13.3	15.7
DRY COOLER									
Model	Kg/h	OPCME20A	OPCME25A		OPCME30A		OPCME35A	OPCME25A	
Qty	n	1			1		2		
DIMENSIONS AND WEIGHT									
Length	mm	1,480	1,750		2,490			3,095	
Depth	mm	890	890		890			890	
Height	mm	1,960	1,960		1,960			2,050	
Weight	Kg	415	620	670	770	780	900	1,210	1,250
AIR COOLED CONDENSER (OUTDOOR UNIT)									
Qty	n	1	2						
CERTIFICATIONS & STANDARDS									
Quality & Compliance ⁽⁶⁾	ISO 9001:2008 ; ISO 14001:2004 ; ISO 13485:2003 ; OHSAS 18001:2007 ; CE								

(1) — FC DXA: Free-cooling plus direct expansion cooled with air

(2) — All specifications apply for U: Upflow and D: Downflow discharge.

(3) — Return air dry bulb temperature 24 °C, RH 50%, Outdoor dry bulb temperature 35 °C

(4) — The free cooling capacity rated at: Return air 24° C DB, 50% R.H.; external air temperature: 2° C DB

(5) — The above capacities of heater and humidifier are standard. Other customized option are available

(6) — CQC31-439125-2010 Energy saving standard apply only to 40, 60, 70, 80 KW models

SY-G reserves the right to change or modify product design, construction, specifications, or materials without prior notice and without incurring any obligation to make such changes and modifications on SY-G products previously or subsequently sold.

OUTDOOR UNIT FEATURES

- Remote aluminum built air-cooled condenser with axial fan (DXA)
- Built entirely in heavy gauge corrosion resistant aluminum
- Aluminum fins and copper tubes staggered in direction of the airflow
- Fan speed is step-less controlled by microprocessor according to compressor discharge pressure
- Outdoor service valves

BENEFITS:

- Designed and manufactured to operate at 3,000 meters above sea level without suffering any degradation
- Can be installed in either vertical or horizontal air discharge, for footprint considerations
- Fan motor provides steady operation, lower noise level, energy savings and low temperature start-up



TECHNICAL SPECIFICATIONS: OUTDOOR UNIT FOR EMPEROR SERIES DXA⁽¹⁾ & FC 35 KW TO 100 KW

UNIT MODEL	OPCME8SLA	OPCME10SLA	OPCME15SLA	OPCME20SLA
Qty of fan	n	1	1	2
Input power	Kw	0,63	0,74	1,26
Input current	A	3,0	3,4	6
CONNECTION TUBE SIZE				
Gas pipe	ODF	22		28,0
Liquid pipe	ODF	16,0	19,0	
DIMENSIONS				
Length	mm	1.340	1.540	2.400
Width	mm	620	620	630
Height	mm	1.070	1.070	1.135
Weight	Kg	95	110	155

(1) – DXA FC: Direct expansion cooled with air, and direct expansion cooled with air plus free cooling

(2) – The capacity is rated at entering air temperature 35 oC and condensing temperature 50 condition.

(3) – The noise is measured at 1 meter distance from unit at open field on condenser coil side according to ISO 3744

Vertical installation

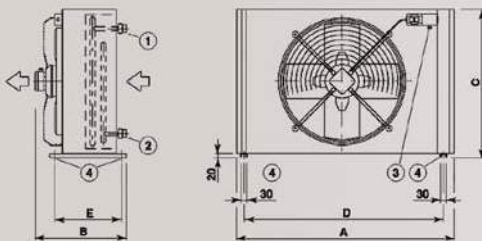

Horizontal installation

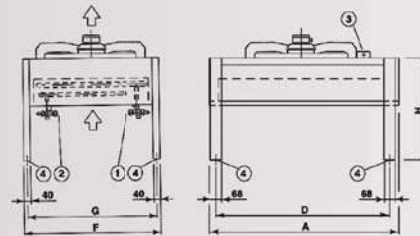

Horizontal installation

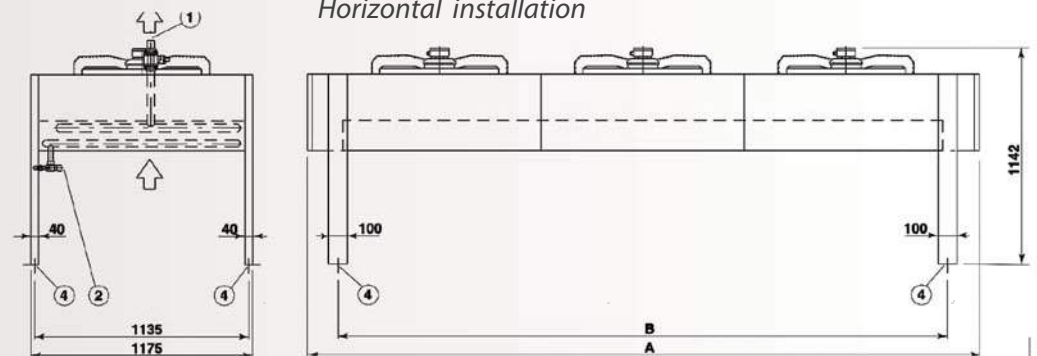

TECHNICAL SPECIFICATIONS
INDOOR UNIT FOR:
EMPEROR SERIES DXW⁽¹⁾
35 KW TO 100 KW



UNIT MODEL	PPUW35SHAO	PPUW40SHAO	PPUW50SHAO	PPUW60SHAO	PPUW70A0	PPUW80SHAO	PPUW90SHAO	PPUW100SHAO	
	PPDW35SHAO	PPDW40SHAO	PPDW50SHAO	PPDW60SHAO	PPDW70A0	PPDW80SHAO	PPDW90SHAO	PPDW100SHAO	
Supply air scheme ⁽²⁾					U: Upflow	D: Downflow			
POWER SUPPLY									
Power source	208 - 230V, 3Ph, 60Hz								
COOLING CAPACITY ⁽³⁾									
Total	KW [Btu/h]	36.8 [125,566]	42.9 [146,380]	53.8 [183,573]	62.8 [214,282]	72.6 [247,721]	82.6 [281,842]	90.6 [309,140]	103.8 [354,180]
Sensible	KW [Btu/h]	33.9 [115,671]	39.9 [136,144]	49.6 [169,242]	58.5 [199,610]	67.2 [229,295]	78.1 [266,488]	83.1 [283,549]	97.2 [331,660]
SUPPLY FANS									
Qty of fan	n	1	2		3				
Air volume	m3/h [CFM]	9,600 [5,650]	12,750 [7,504]	12,300 [7,240]	19,200 [11,301]	19,100 [11,242]		28,960 [17,045]	
COMPRESSOR									
Type	Hermetic scroll compressor								
Qty of Compressor		1	2						
FILTERS									
Type	G4								
ELECTRIC HEATER									
Heating capacity ⁽⁴⁾	KW	9	13.5			18			
HUMIDIFIER									
Humidifying capacity ⁽⁴⁾	Kg/h	5	8			15			
Power	KW	3.8	5.9			11.3			
DIMENSIONS AND WEIGHT									
Length	mm	1,480	1,750		2,490			3,095	
Depth	mm	890	890		890			890	
Height	mm	1,960	1,960		1,960			2,050	
Weight	Kg	420	630	680	940	980	1,040	1,230	1,270
WATER CONDENSER ⁽⁵⁾									
Water flow	m3/h	7.3	11	12.4	14.1	16	18.1	20.3	23.7
Pressure drop	KPa	26	46.4	44.3	44.8	46.3	48.4	34.3	36.7
Pressure drop (with valves)	KPa	47.5	63.4	62.8	58.3	61.3	69.9	51.8	55.2
Volume	KPa	2.2	4	4.5	5.2	5.8	6.4	7.3	8.1
CERTIFICATIONS & STANDARDS									
Quality & Compliance ⁽⁶⁾	ISO 9001:2008 ; ISO 14001:2004 ; ISO 13485:2003 ; OHSAS 18001:2007 ; CE								

(1) — DXW: Direct expansion cooled with water

(2) — All specifications apply for U: Upflow and D: Downflow discharge.

(3) — Return air dry bulb temperature 24 °C, RH 50 %, Outdoor dry bulb temperature 35 °C

(4) — The above capacities of heater and humidifier are standard. Other customized option are available

(5) — To match the internal unit with an appropriate outdoor condenser, follow these parameters. At the moment Sy-G does not offer water condensers

(6) — CQC31-439125-2010 Energy saving standard apply only to 40, 60, 70, 80 KW models

SY-G reserves the right to change or modify product design, construction, specifications, or materials without prior notice and without incurring any obligation to make such changes and modifications on SY-G products previously or subsequently sold.

TECHNICAL SPECIFICATIONS
INDOOR UNIT FOR
EMPEROR SERIES CW⁽¹⁾
40 KW TO 160 KW



UNIT MODEL		PPUC40SHAO	PPUC65SHAO	PPUC80SHAO	PPUC100SHAO	PPUC120SHAO	PPUC160SHAO
		PPDC40SHAO	PPDC65SHAO	PPDC80SHAO	PPDC100SHAO	PPDC120SHAO	PPDC160SHAO
Supply air scheme ⁽²⁾		U: Upflow			D: Downflow		
POWER SUPPLY							
Power source		208 - 230V, 3Ph, 60Hz					
COOLING CAPACITY ⁽³⁾							
Total	KW [Btu/h]	43.0 [146,722]	55.6 [189,715]	84.3 [287,643]	105.4 [359,639]	126.9 [433,000]	160.3 [546,966]
Sensible	KW [Btu/h]	40.4 [137,850]	51.9 [177,090]	78.9 [269,218]	98.1 [334,731]	119.3 [407,068]	148.6 [507,044]
COOLING COIL ⁽³⁾							
Water flow	m3/h	7.4	9.6	14.5	18.2	21.6	27.5
Pressure drop	kPa	44.7	48.1	69.8	72	58.1	74.7
SUPPLY FANS							
Qty of fan	n	1		2		3	
Air volume	m3/h [CFM]	10,500 [6,180]	13,000 [7,652]	21,000 [12,360]	24,800 [14,597]	31,500 [18,540]	37,200 [21,895]
FILTERS							
Type		G4					
ELECTRIC HEATER							
Heating capacity ⁽⁴⁾	KW	9		13.5		18	
HUMIDIFIER							
Humidifying capacity ⁽⁴⁾	Kg/h	8		15			
DIMENSIONS AND WEIGHT							
Length	mm	1,235		1,980		2,490	2,905
Depth	mm	900		900		900	900
Height	mm	2,320		2,320		2,320	2,320
Weight	Kg	375	405	525	560	750	890
CERTIFICATIONS & STANDARDS							
Quality & Compliance ⁽⁵⁾		ISO 9001:2008 ; ISO 14001:2004 ; ISO 13485:2003 ; OHSAS 18001:2007 ; CE					

(1) — CW: Cooled with chilled water

(2) — All specifications apply for U: Upflow and D: Downflow discharge.

(3) — Return air dry bulb temperature 24 °C, RH 50%, inlet/outlet chilled water temperature 7°C/12°C

(4) — The above capacities of heater and humidifier are standard. Other customized option are available

(5) — CQC31-439125-2010 Energy saving standard apply only to 40, 60, 70, 80 KW models

SY-G reserves the right to change or modify product design, construction, specifications, or materials without prior notice and without incurring any obligation to make such changes and modifications on SY-G products previously or subsequently sold.

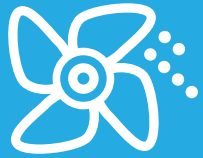

WALL-FIT PRECISION AIR CONDITIONERS

ACHIEVER SERIES

10 - 15 KW

INDOOR UNIT STANDARD FEATURES

- Constructed with a steel frame and painted with epoxy powder to ensure proper adhesion to the surface
- Microprocessor control system with LCD display
- Electronic thermostat for temperature control
- R410A environmentally-friendly refrigerant
- Equipped with double inlet, three speed adjustable, directly-coupled centrifugal fan (no belts and pulleys)
- Independent electrical protections for compressor, fan, motor, heater, and humidifier
- Electric resistance heaters with temperature control, built with low density heating components and non-corrosive metal sheath tubular finned
- Self-contained immersed electrode boiler type humidifier with water level control and auto-drain functions (separate chassis)
- Voltage supervisor with phase sensor.
- Automatic start after a power failure
- Thermodynamic expansion valve (TXV)
- Liquid detection sensor
- Independent refrigerant charging system for high and low pressure lines
- Indoor service valves

OPTIONAL FEATURES

- Electronic expansion valve (EXV)
- Touch-screen display for the controller
- Multiple communication protocols for remote monitoring, such as: SNMP (web interface), Modbus and BACnet.
- Can be designed and manufactured to operate at 3,000 meters above sea level without suffering any degradation

BENEFITS:

- Capability for cooling, heating, de-humidifying, and humidifying, as well as filtering air in the room
- Provide high Sensible Heat Ratio (SHR) and world-class Energy Efficiency Ratio (EER)
- Versatile wall-mount installation
- Directly-coupled centrifugal fans are 35% more efficient, have an average lifespan of 10 to 15 years, and for ease of maintenance, there are no belts to change or pulleys to adjust
- The control system allows customized programming of temperature, relative humidity, and manual start-up of components, etc.
- Compressor positive start to avoid short-cycling alarms and low-pressure lockout
- Highly accurate temperature and humidity control that extends the service interval and life-cycle, designed to operate with ordinary tap water and equipped with automatic water supply and flushing system to reduce mineral precipitation



Outdoor unit



Indoor unit



Humidifier chassis



**ESPECIFICACIONES TÉCNICAS:
UNIDAD INTERNA DE LA SERIE
ACHIEVER DXA⁽¹⁾ 10 A 15 KW**

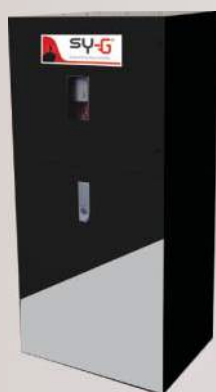
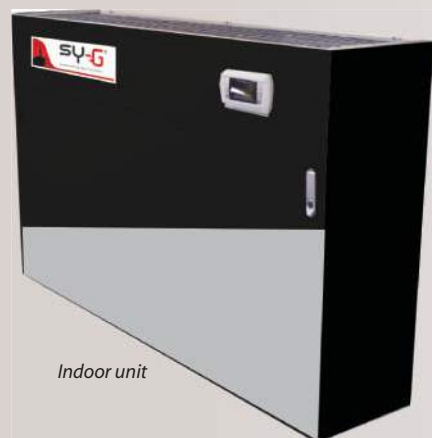

UNIT MODEL		WPUA10SL1PAS	WPUA13SL1PAS	WPUA15AS
Supply air scheme		U: Upflow		
POWER SUPPLY				
Power source		208 - 230V, 1Ph, 60Hz		
COOLING CAPACITY ⁽²⁾				
Total	KW [Btu/h]	10.7 [36,509]	13.0 [44,357]	15.00 [51,182]
EVAPORATOR FAN				
Type		Double inlet centrifugal fan		
Qty of fan	n	1		
Air Volume	m3/h [CFM]	1,600 [941]	2,000 [1,177]	6,650 [1,560]
COMPRESSOR				
Type		Hermetic scroll compressor		
Qty of Compressor		1		
REFRIGERANT				
Type		R410A		
Control		Thermal expansion valve		
CONDENSING UNIT FAN				
Qty of fan	n	1		
Air Volume	m3/h [CFM]	1,440 [847]	1,305 [768]	1,305 [768]
DIMENSIONS AND WEIGHT				
Width	mm	1.295		
Depth	mm	310		
Height	mm	870		
Weight	Kg	64	67	69
CERTIFICATIONS & STANDARDS				
Quality & Compliance		ISO 9001:2008 ; ISO 14001:2004 ; ISO 13485:2003 ; OHSAS 18001:2007 ; CE		

(1) — Direct expansion cooled with air

(2) — Return air dry bulb temperature 24°C, H 50 %, wet bulb temperature 19°C. Outdoor dry bulb temperature 35 , wet bulb temperature 24 °C
SY-G reserves the right to change or modify product design, construction, specifications, or materials without prior notice and without incurring any obligation to make such changes and modifications on SY-G products previously or subsequently sold.



OUTDOOR UNIT FEATURES

- Remote air-cooled condensing unit with axial fan (DXA)
- Aluminum fins and copper tubes staggered in direction of the airflow
- Hermetic scroll compressor, installed in the outdoor unit and equipped with electrical protector, phase protector, exhaust muffler, and oil tank heater
- Fan speed is step-less controlled by microprocessor according to compressor discharge pressure
- Outdoor service valves

BENEFITS:

- Outdoor compressor installation reduces the size of the indoor unit
- Fan motor provides steady operation, lower noise level, energy savings and low temperature start-up

TECHNICAL SPECIFICATIONS: OUTDOOR UNIT FOR ACHIEVER SERIES DXA⁽¹⁾ 10 KW TO 15 KW

MODEL		OPCND10SLA	OPCND13SLA
Compressor ⁽²⁾	Type * Qty	Hermetic Scroll * 1	
Qty of fan		1	2
Gas pipe	∅	3/4"	3/4"
Liquid pipe	∅	1/2"	1/2"
Length	mm	590	590
Width	mm	1440	1305
Height	mm	1125	1500
Weight	Kg	123	145

(1) — DXA: Direct expansion cooled with air, and direct expansion cooled with air plus free cooling

(2) — Outdoor unit is a condensing unit since it carries the system's compressor

Vertical installation

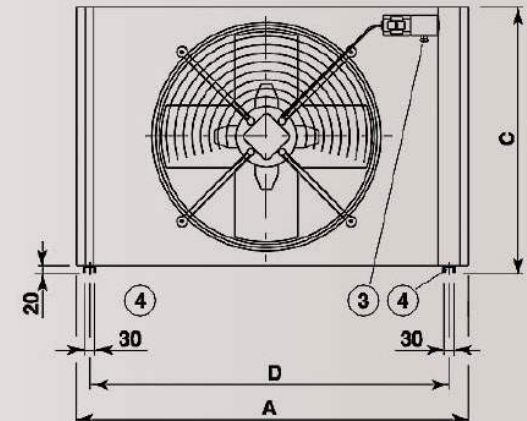
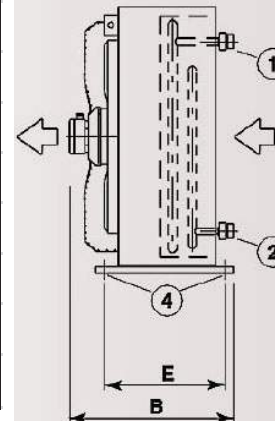

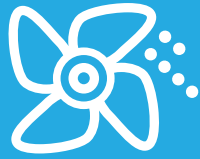

INROW PRECISION AIR CONDITIONERS PC SERIES

SIDEKICK SERIES

24 & 38 KW

FEATURES

- Constructed with a steel frame and painted with epoxy powder to ensure proper adhesion to the surface
- Microprocessor control system with LCD display
- Equipped with EC centrifugal fan (no belts and pulleys)
- Aluminum water pan with drainpipe
- Self-contained immersed electrode boiler type humidifier with water level control and auto-drain functions (Only in 38 kW units)
- Leak detection sensor
- R410A environmentally-friendly refrigerant
- Electric resistance heaters with temperature control, built with low density heating components and non-corrosive metal sheath tubular finned (Only in 38 kW units)
- Independent electrical protections for: compressor, fan, motor, heater, and humidifier
- Hermetic DC inverter scroll compressor equipped with: electrical protector, phase protector, exhaust muffler, and oil tank heater
- Thermostatic expansion valve (TXV)
- Washable nylon net air filters built with an exterior aluminum mount structure
- Indoor service valves

BENEFITS:

- New solution to increase energy efficiency for data centers. Units are installed between server cabinets, closely with the heat load, avoiding hot and cold air mixture. The system efficiency increases by 30% to 45% compared with traditional cooling system
- High capability for cooling, heating, de-humidifying, and humidifying, as well as filtering air in the room
- Provides high Sensible Heat Ratio (SHR) and world-class Energy Efficiency Ratio (EER)
- Can be designed and manufactured to operate at 3,000 meters above sea level without suffering any degradation
- Random multiple units insertion after a power failure, with a time delay from 2 to 60 seconds, avoiding simultaneous starting of the units
- The control system allows customized programming of temperature, relative humidity, and manual start-up of components. In addition, up to sixteen (16) units can be installed to function synchronously in parallel, alternating, and/or in redundant configurations
- Optional energy saving working mode
- Compressor positive start to avoid short-cycling alarms and low-pressure lockout
- Highly accurate temperature and humidity control (Only for 38 KW model) that extends the service interval and life-cycle, designed to operate with ordinary tap water and equipped with automatic water supply and flushing system to reduce mineral precipitation
- For an easy configuration units are independent. The system can still run normally when one unit fails.
- Convenient Installation. The unit has four height-adjustable fixed legs. It makes it easier to remove and install the unit. Besides, top or bottom pipe and line connection can be chosen according to customer's demand
- Front and rear service access. Don't need to remove the unit at maintenance and don't influence other normal working units.
- Electric board, protection switches and control devices are installed in a separated compartment, making the unit serviceable without requiring shut down
- Available for places no matter with raised floor or not, also available for both newly built data center and reconstruction project;
- Saving Operation Cost: Short supply airflow path, decreasing fan power consumption.

OPTIONAL FEATURES

- Touch screen display for controller
- Multiple communication protocols for remote monitoring, such as: SNMP (web interface), Modbus and BACnet.
- Air pressure switch for clogged filter alarm
- Phase sequence protection relay for power supply



**TECHNICAL SPECIFICATIONS:
INDOOR UNIT FOR SIDEKICK
24 & 38 KW SERIES
DXA⁽¹⁾ 24 KW & 38 KW**



UNIT MODEL		IPFA24FHAC	IPFA38FHAC
Supply air scheme ⁽²⁾		F: Front	
POWER SUPPLY			
Power source		380V, 3Ph, 50Hz	
COOLING CAPACITY ⁽³⁾			
Total capacity	KW [Btu/h]	24.2 [82,574]	38.7 [132,050]
Sensible capacity	KW [Btu/h]	24.2 [82,574]	38.7 [132,050]
SUPPLY FAN			
Type		DC powerd EC centrifugal fan	AC powered EC centrifugal fan
Qty of fan	n	1	
Air Volume	m3/h [CFM]	4,560 [2,683]	11,600 [6,827]
COMPRESSOR			
Type		Hermetic DC inverter scroll compressor	
Qty of Compressor		1	
REFRIGERANT			
Type		R410A	
Control		Thermal expansion valve	
FILTERS			
Type		Washable nylon net	
Qty of filters	n	1	
ELECTRIC HEATER			
Type		Stainless steel	
Working class	n.	0	1
Heating capacity ⁽⁴⁾	KW	0.0	9.0
HUMIDIFIER			
Type		Electrode	
Humidifying capacity ⁽⁴⁾	Kg/h	0	3
DIMENSIONS AND WEIGHT			
Width	mm	300	600
Depth	mm	1180	1180
Height	mm	2,000	2,000
Weight	Kg	140	370
OUTDOOR UNIT			
Model ⁽⁵⁾		OPCRM10A	OPCME15A
Qty	n.	1	
CERTIFICATIONS & STANDARDS			
Quality		ISO 9001:2008 ; ISO 14001:2004 ; ISO 13485:2003 ; OHSAS 18001:2007	
Compliance			

(1) — DXA: Direct expansion cooled with air

(2) — All specifications apply for U: Upflow, D: Downflow and L: Lower front discharge.

(3) — Return air dry bulb temperature 37 °C, RH 50 %, Outdoor dry bulb temperature 35 °C.

(4) — The above capacities of heater and humiditifier are standard. Other customized option are available

(5) — For technical specifications of outdoor unit, please refer to the next table: Outdoor Unit Technical Specifications for: PP Series DXA 10 KW to 30 KW at 50/60 Hz
SY-G reserves the right to change or modify product design, construction, specifications, or materials without prior notice and without incurring any obligation to make such changes and modifications on SY-G products previously or subsequently sold.

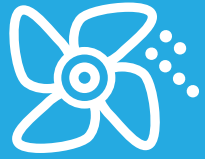

PACKAGED AIR CONDITIONERS

REBEL SERIES

3 - 5 KW

FEATURES

- Designed to be side-mounted on cabinets
- Equipped with directly-coupled axial fan (no belts and pulleys)
- Independent electrical protections for compressor and fan
- Hermetic scroll compressor

BENEFITS:

- Wide variety of configurations to fit enclosures
- Highly accurate temperature control
- Directly-coupled axial fan; for ease of maintenance, there are no belts to change or pulleys to adjust



**TECHNICAL SPECIFICATIONS
FOR: REBEL SERIES 3 TO 5 KW**



UNIT MODEL		PCLA3SL1PAT	PCLA5SL1PAT
Supply air scheme		L: Lower front discharge	L: Lower front discharge
COOLING CAPACITY			
Total capacity	KW [Btu/h]	3.06 [10,441]	5.00 [17,060]
POWER SUPPLY			
Power source		220 V ±15%, 1 Ph, 60Hz	220 V ±15%, 1 Ph, 60Hz
RATED POWER			
Rated Power	W	1320	1760
REFRIGERANT			
Type		R134A	R134A
IP GRADE			
IP		55	55
WORKING TEMPERATURE			
Working Temperature range		-40°C ~ 55°C	-10°C ~ 50°C
Noise			
Noise	dB	70	67
DIMENSIONS AND WEIGHT			
Width	mm	549	549
Depth	mm	220	251
Height	mm	1.208	1.336
CERTIFICATIONS & STANDARDS			
Quality		ISO 9001:2008 / ISO 14001:2004 / ISO 13485:2003 / OHSAS 18001:2007	ISO 9001:2008 / ISO 14001:2004 / ISO 13485:2003 / OHSAS 18001:2007
Compliance		EN60529:1991 ; CE	EN60529:1991 ; CE

SY-G reserves the right to change or modify product design, construction, specifications, or materials without prior notice and without incurring any obligation to make such changes and modifications on SY-G products previously or subsequently sold.

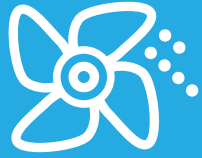

PACKAGED AIR CONDITIONERS

EXPLORER SERIES

5 - 18 KW

FEATURES

- Constructed with a steel frame with corrosion protection treatment
- Equipped with AC directly-coupled centrifugal fan (no belts and pulleys)
- R407C environmentally-friendly refrigerant
- Independent electrical protections for compressor, fan, and motor
- Hermetic scroll compressor equipped with: electrical protector, phase protector, exhaust muffler, and oil tank heater
- Thermodynamic expansion valve (TXV)
- Washable G4 fiber-pad folded filter, built with and exterior aluminum mount structure
- Wall-mounting kit
- Indoor and outdoor service valves

OPTIONAL FEATURES:

- Electronically-Commutated (EC) fan
- Electronic expansion valve (EXV)
- Microprocessor control system with PLD display
- Electric heaters
- Can be design and manufacture to operate at 3,000 meters above sea level without suffering any degradation
- Free-cooling system

BENEFITS:

- Versatile outdoor wall-mount installation that saves internal space
- Highly accurate temperature control
- Energy savings with free-cooling system
- AC directly-coupled centrifugal fans are 35% more efficient, have an average lifespan of 10 to 15 years
For ease of maintenance, there are no belts to change or pulleys to adjust
- Automatic self- diagnosis through continuous testing of all components connected to the microprocessor
- Random multiple units insertion after a power failure, with a time delay from 2 to 60 seconds, avoiding simultaneous starting of the units
- Air filter with high torque and low leakage air damper
- Front serviceable with easy access to all major components



**TECHNICAL SPECIFICATIONS FOR:
EXPLORER SERIES
5 KW TO 18 KW**



UNIT MODEL		PCLF8SHAM	PCLF10SHAM	PCLF13SHAM	PCLF15SHAM	PCLF18SHAM
Supply air scheme		L: Lower front discharge				
POWER SUPPLY						
Power source		208 - 230V, 1Ph, 60Hz				
COOLING CAPACITY						
Free cooling capacity	KW [Btu/h]	7.9 [26,955]	8.6 [29,344]	9.1 [31,050]	15.2 [51,865]	
SUPPLY FAN						
Type		AC centrifugal fan				
Qty of fan	n	1				
Air Volume	m3/h [CFM]	2,300 [1,353]	2,400 [1,413]	2,600 [1,530]	2,750 [1,619]	
COMPRESSOR						
Type		Hermetic scroll compressor				
Qty of Compressor		1				
REFRIGERANT						
Type		R407C				
Control		Thermal expansion valve				
FILTERS						
Preliminary Filter Type		G2 (Nylon net)				
Main Filter Type		G3 (Disposable pleated)				
Qty of filters	n	1 of each type				
ELECTRIC HEATER						
Type		Finned stainless tube				
Heating capacity	KW	4.5				
DIMENSIONS AND WEIGHT						
Width	mm	930	1,080	1,280		
Depth	mm	700				
Height	mm	2,140				
Weight	Kg	240	270	305	320	402
CONDENSER FAN						
Type		Axial Fan				
Qty	n.	1				2
Air Volume	m3/h [CFM]	4,050 [2,383]	5,900 [3,473]	6,300 [3,708]	8,050 [4,738]	
CERTIFICATIONS & STANDARDS						
Quality & Compliance		ISO 9001:2008 ; ISO 14001:2004 ; ISO 13485:2003 ; OHSAS 18001:2007 ; CE				

(1) — The cooling capacity at indoor temp. is 24 °C, at RH 50% and outdoor temp. 35 °C

(2) — CE standard apply only to 10 and 13 KW models

SY-G reserves the right to change or modify product design, construction, specifications, or materials without prior notice and without incurring any obligation to make such changes and modifications on SY-G products previously or subsequently sold.



TECHNICAL FLOORING SOLUTIONS

World-class technical flooring solutions specially designed to achieve modularity, efficiency, and security. Sy-G offers a complete range of solutions, as well as a suite of accessories for maximum performance.



INDEX

CATEGORY

TECHNICAL FLOORING SOLUTIONS



The flooring system complies with the National Standard, Grade A-1 for fire performance-rating under ASTM E84-01 (Standard Test Method for Surface Burning Characteristics of Building Materials), categorized as incombustible with zero (0) flame speed index and zero (0) smoke density rating. The system also has a 106 - 1010 Ω static dissipative resistance.

Our Technical Flooring solutions portfolio includes two different types of products: Raised Access Floor and ESD Vinyl Tiles.

RAISED ACCESS FLOOR

ELECTROSTATIC DISCHARGE (ESD) VINYL TILES



NOMENCLATURE

Series	Material Type	Load Capacity (lbf) or Perforation Percentage	Internal Code	
MC: Mission Critical OA: Office Applications	FS: Filled Steel WC: Wood Core CS: Calcium Sulphate PPS: Perforated Panels Steel PPA: Perforated Panels Aluminum	650 : 2000 <hr/> 25 56	Internal Kardex Code	
Model	MC	FS	1000	ZI

*Note: For perforated panels, instead of load capacity the value is associated with perforation percentage.



RAISED ACCESS FLOOR

Raised access floor designed for mission-critical applications (e.g. data centers, telecom switch centers, call centers, etc.), where underfloor cooling distribution and cable management is important. Raised access floor systems consist of two main components: the understructure and the panels (specific design according to different applications).

Understructure



FEATURES

- *Constructed of galvanized steel to eliminate zinc whiskers*
- *The bolted stringer system integrates pedestal bases, adjustable pedestal heads, stringers, and fasteners*
- *The standard pedestal height ranges from 4" (102 mm) to 48" (1222 mm) and are manufactured to comply with customized specifications*
- *Optional entry ramps or steps*
- *Optional seismic brace, which can be easily attached to any pedestals for ultimate lateral support*

BENEFITS:

- *Provides a strong and secure platform for mission-critical equipment*
- *A higher durability than competitor products due to its high quality materials*
- *Flexibility and modularity, to meet any customers' requirements*





MISSION-CRITICAL APPLICATIONS

MC SERIES

CONCRETE FILLED STEEL

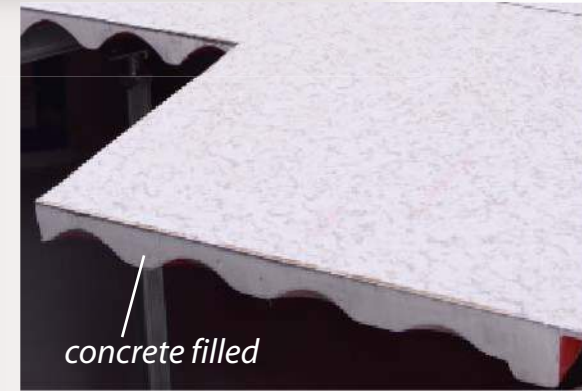
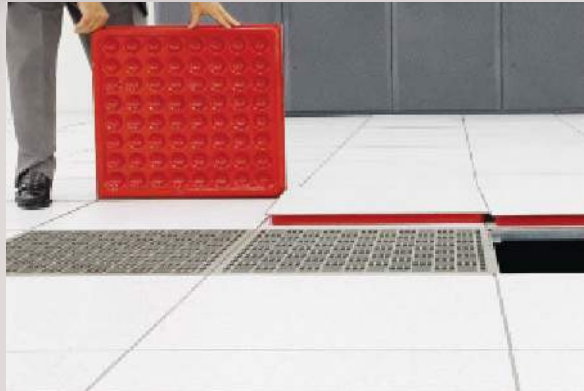

FEATURES

- The panel is built with high-quality deep-stretched steel; on top SPCC material and for the bottom ST14 material, both joint together by resistance welding. The panel is painted with epoxy powder and infilled with light cement.
- The top steel sheet of the panel is stuck-on with anti-wear and a 1.6 antistatic High-Pressure Lamination (HPL)
- The panel systems are available in both metric standard (600 mm x 600 mm) and imperial standard (24" x 24")
- The panels are finished with integral trim technology that reduces chipping

BENEFITS:

- Robust and stable support structure. A higher durability than competitor products due to its high quality materials (e.g. HPL core, manufactured from virgin paper to eliminate cracking)
- Safety and standard accomplishment (IEC 61000-4-2 & TIA-942)
- Distinguished decorative finish

TECHNICAL SPECIFICATIONS: MC SERIES CONCRETE FILLED STEEL

MODEL	Concentrated Load			Impact Load		Ultimate Load		Uniform Load		Rolling Load				Average System Weight per m2
	N	kgf	lbf	N	kgf	N	kgf	N/m2	kgf/m2	10 passes		10,000 passes		
										N	kgf	N	kgf	
MCFS800ZI	≥3,596	≥367	≥808.41	780	80	≥10,799	≥1,101	≥19,796	≥2,019	≥2,959	≥302	≥2,215	≥226	39.34
MCFS1000ZI	≥4,498	≥459	≥1011.19	780	80	≥13,494	≥1,376	≥23,294	≥2,375	≥3,596	≥367	≥2,959	≥302	43.46
MCFS1250ZI	≥5,595	≥571	≥1257.81	780	80	≥16,797	≥1,713	≥33,084	≥3,374	≥4,498	≥459	≥3,596	≥367	51.73
MCFS1500ZI	≥6,693	≥682	≥1504.65	780	80	≥20,090	≥2,049	≥42,581	≥4,342	≥5,595	≥571	≥4,498	≥459	55.75
MCFS2000ZI	≥8,898	≥907	≥2000.35	780	80	≥26,685	≥2,721	≥49,784	≥5,077	≥6,693	≥682	≥5,595	≥571	64.12

(1) — Certifications & Standards: ISO 9001 ; ISO 14001 ; CE ; CISCA ; VOC ; TUV

SY-G reserves the right to change or modify product design, construction, specifications, or materials without prior notice and without incurring any obligation to make such changes and modifications on SY-G products previously or subsequently sold.





MISSION CRITICAL APPLICATIONS

MC SERIES

PERFORATED PANELS

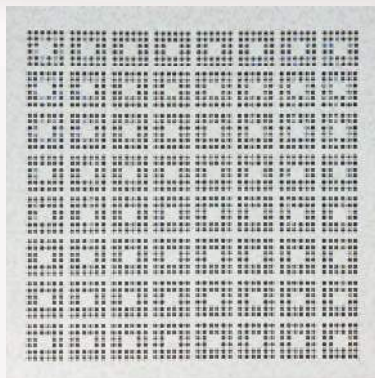

FEATURES

- Exactly the same size and finish as anti-static solid panels, but built with hollow cavity
- Steel and aluminum panels are punched with ventilation holes
- Perforated panels vary from 25% to 56% perforations
- The panel systems are available in both metric standard (600 mm x 600 mm) and imperial standard (24" x 24")
- Slide damper (optional)

BENEFITS:

- Steel and aluminum-perforated panels allow underfloor air conditioning to flow through the floor up to equipment

TECHNICAL SPECIFICATIONS: MC SERIES PERFORATED PANELS

Type	Concentrated Load			Safety Factor
	N	Kgf	lbf	
MCPPA56ZI	6672.33	3300	1500	>2
MCPPS25ZI	404.79	200.2	91	

(1) — Certifications & Standards: ISO 9001 ; ISO 14001 ; CE ; CISCA ; VOC ; TUV

prior notice and without incurring any obligation to make such changes and modifications on Sy-G products previously or subsequently sold.





OFFICE APPLICATIONS

OA SERIES

CONCRETE FILLED STILL

Raised access floor designed for spaces that need flexible installation and easy layout of cabling and wiring, such as telecommunication rooms, computer rooms, banks, smart offices and other anti-static requiring places.



FEATURES

- The panel is constructed with still plate. For the bottom, ST14 material is used, while for the top SPCC.
- The panel is coated with epoxy paint and infilled with light cement.
- The panel systems are available in metric standard (600 mm x 600 mm) and imperial standard (24" x 24")

BENEFITS:

- Robust and light-weight
- Isolates noise
- Particularly suitable for areas of high humidity.
- High-quality, durable materials
- Modularity and Flexibility

TECHNICAL SPECIFICATIONS: OA SERIES CONCRETE FILLED STILL

MODEL	Size	Concentrated Load			Impact Load		Ultimate Load		Uniform Load		Rolling Load				Average System Weight per m2
		N	kgf	lbf	N	kgf	N	kgf	N/m2	kgf/m2	10 passes		10,000 passes		
	mm	N	kgf	lbf	N	kgf	N	kgf	N/m2	kgf/m2	N	kgf	N	kgf	kg
OAFS668ZI	600 x 600 x 35	≥2,290	≥234	≥514.18	780	80	≥8,890	≥908	≥12,500	≥1274.88	≥2,215	≥226	≥1,548	≥158	33.34
OAFS800ZI	600 x 600 x 35	≥3,596	≥367	≥808.41	780	80	≥10,799	≥1,101	≥19,796	≥2,019	≥2,959	≥302	≥2,215	≥226	39.34
OAFS1000ZI	600 x 600 x 35	≥4,498	≥459	≥1011.19	780	80	≥13,494	≥1,376	≥23,294	≥2,375	≥3,596	≥367	≥2,959	≥302	43.46
OAFS1250ZI	600 x 600 x 35	≥5,595	≥571	≥1257.81	780	80	≥16,797	≥1,713	≥33,084	≥3,374	≥4,498	≥459	≥3,596	≥367	51.73
OAFS1500ZI	600 x 600 x 35	≥6,693	≥682	≥1504.65	780	80	≥20,090	≥2,049	≥42,581	≥4,342	≥5,595	≥571	≥4,498	≥459	55.75
OAFS2000ZI	600 x 600 x 35	≥8,898	≥907	≥2000.35	780	80	≥26,685	≥2,721	≥49,784	≥5,077	≥6,693	≥682	≥5,595	≥571	64.12

(1) — Certifications & Standards: ISO 9001 ; ISO 14001 ; CE ; CISCA ; VOC ; TUV

SY-G reserves the right to change or modify product design, construction, specifications, or materials without prior notice and without incurring any obligation to make such changes and modifications on SY-G products previously or subsequently sold.



OFFICE APPLICATIONS

OA SERIES WOOD CORE

Raised access floor designed for spaces that need flexible installation and easy layout of cabling and wiring, such as telecommunication rooms, computer rooms, banks, smart offices and other anti-static requiring places.

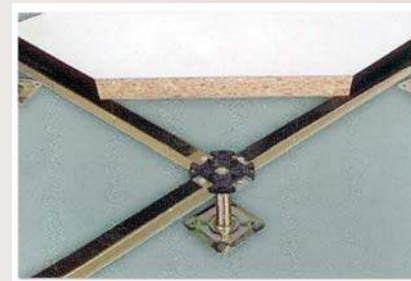
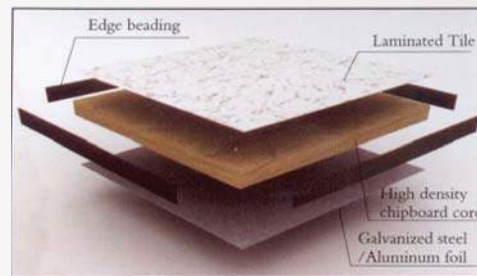

FEATURES

- The panel is constructed with high-density chipboard core encapsulated in full galvanized steel encasement.
- The panel systems are available in metric standard (600 mm x 600 mm) and imperial standard (24" x 24")
- 1.6 mm anti-static High Pressure Lamination (HPL)

BENEFITS:

- Robust and light-weight
- Isolates noise
- Particularly suitable for areas of high humidity.
- High-quality, durable materials (e.g. HPL core, which is manufactured from virgin paper to eliminate cracking)
- Elegant decorative finish

TECHNICAL SPECIFICATIONS: OA SERIES WOOD CORE

TYPE	Concentrated Load			Impact Load	Ultimate Loas	Uniform Load	Rolling Load	
	N	Kgf	lbf				10	10000
OAWC650ZI	≥2990	≥1478	≥672.17	670	≥8890	≥12500	2215	1548
OAWC800ZI	≥3596	≥1778	≥808.41	670	≥10799	≥19796	2959	2215
OAWC1000ZI	≥4498	≥2224	≥1011.19	670	≥13494	≥23294	3596	2959

(1) — Certifications & Standards: ISO 9001 ; ISO 14001 ; CE ; CISCA ; VOC ; TUV

Sy-G reserves the right to change or modify product design, construction, specifications, or materials without prior notice and without incurring any obligation to make such changes and modifications on Sy-G products previously or subsequently sold.



OFFICE APPLICATIONS OA SERIES

OA SERIES CALCIUM SULPHATE



FEATURES

- Calcium sulphate core, steel bottom surface, HPL or PVC top surface, and PVC edges
- Easy to interchange other types of panels
- The panel systems are available in both metric standard (600 mm x 600 mm) and imperial standard (24" x 24")

BENEFITS:

- High-strength panels for intensive loads
- Excellent mechanical properties
- Waterproof, fireproof, and rot-proof
- Acoustic absorption
- Reduced sensitivity to humidity and temperature
- Outstanding antistatic performance
- Good sealing

TECHNICAL SPECIFICATIONS: OA SERIES CALCIUM SULPHATE

Type	Concentrated Load			Impact Load	Ultimate Load	Uniform Load	Rolling Load	
	N	Kgf	lbf				10	10000
OACS1000ZI	≥4498	≥2224	≥1011.19	670	≥13494	≥23294	3596	2959
OACS1200ZI	≥5595	≥2767	≥1257.80	670	≥16797	≥33084	4498	3596

(1) — Certifications & Standards: ISO 9001 ; ISO 14001 ; CE ; CISCA ; VOC ; TUV

SY-G reserves the right to change or modify product design, construction, specifications, or materials without prior notice and without incurring any obligation to make such changes and modifications on SY-G products previously or subsequently sold.





RAISED ACCESS FLOOR

ACCESSORIES

IT GRIDS

IT Grids are an under-the-floor cable routing system to create a versatile pathway to route and manage the data and power network beneath the raised floor. It can be comprised of a single wiring tray, or double wiring tray, where services can be separated:

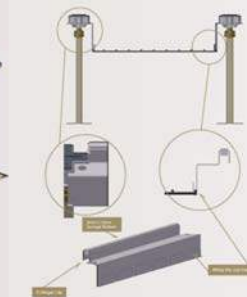
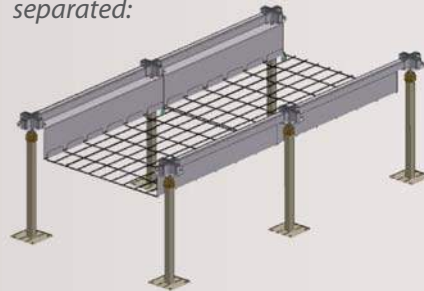

The Single Wiring Tray photo

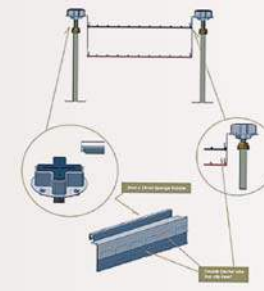

The Double Wiring Tray photo.

BENEFITS:

- Robust construction
- Quick installation
- Integral grounding and bonding

FAN UNITS

Fan units are specially designed to provide cooling support on specific spots of the raised floor. The units have multiple control options to automatically turn on when additional cooling is needed. These powerful solutions are ideal to eliminate the toughest hot spots in data centers.

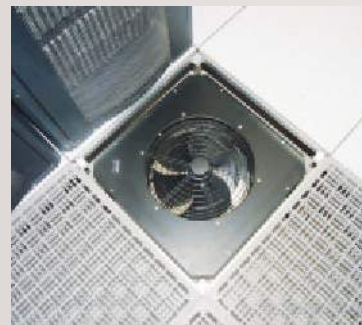

- Multiple control options
- VN, client sensor network
- User programmable set point
- Variable fan speed for precise airflow control



- Easy installation
- No maintenance required
- High-precision, quick-response temperature measurement





RAISED ACCESS FLOOR

ACCESSORIES

AIR GROMMETS

Air Grommets are economic and effective accessories to cover cable openings, eliminate bypass airflow, and optimize the cooling management of the raised floor plenum. Air Grommets are available in a variety of colors and sizes offering various designs and color schemes.

- Reduces air loss and increases under-floor static pressure
- Improves cooling efficiency in the raised floor plenum
- Reduces hot spots
- Lowers energy consumption and improves PUE index
- Prevents under-floor contamination by sealing cable openings
- Extends cooling equipment lifespan



L-MOLDING

L-molding is used to line panel interiors when they have been cut, typically to allow the installation of cables entering through the raised floor, and to prevent plenum air leakage. The rigid plastic is made of injection-molded resins and is resistant to chipping or breakage.



LIFTING DEVICE

Lifting devices allow fast and simple removal of floor panels to make installations and re-designs easy. There are a variety of lifting devices including double-suction cups and airflow panel lifters with very high load ratings and are ready-to-use. They can be easily stored in lifter wall mount brackets.





ELECTROSTATIC DISCHARGE

ESD SERIES

VINYL FLOOR TILES

ESD floor tiles are commonly used for telecom, electronic industries, cell-type machine rooms, computer rooms, and clean rooms that require special conductive or dissipative properties.

FEATURES

- Mainly built of PVC high density resin
- Plastic particle interfaces are used to form a permanent conductive or dissipative matrix
- The vinyl tiles are available in both metric standard (600 mm x 600 mm) and imperial standard (24" x 24")

BENEFITS:

- Abrasion and corrosion resistance
- Ageing resistance providing longer lifespan
- Low dust emissions
- Elegant decorative finish

TECHNICAL SPECIFICATIONS ESD SERIES

ITEM	SDLYD13ZI
THICKNESS	3.0 mm
SIZE	610*610 mm
WEIGHT	5.8 kg
ELECTRIC PROPERTIES DIN511953 ASTM F-150 OR NFPA99	DISSIPATIVE TILE 10 ⁵ ~10 ⁸ OHM
EDCAY TIME SJ/T 10694-2006 (1000V +/- 100V ≤ 2S)	EQUAL 0.4S
CHARGING VOLTAGE SJ/T10694-2006 (V< 100V)	EQUAL 70
FIRE RESISTANCE GRADE DIN4102	B1
COMBUSTION PROPERTIES SJ/T11236-2001 (<10S)	EQUAL 0.35SFV-0
AMOUNT OF ANTI-WEAR SJ/T11236-2001	EQUAL 0.014
ANTI-WEAR PROPERTIES EN660PT2	ITEM-T<2.0mm ³
WHEEL PRESSURE EN25	NO INFLUENCE
RESIDUAL CONCAVITY EN433/DIN51955	0.04 mm
DIMENSIONAL STABILITY EN 434	≥ 0,10%
COLOR FASTNESS ISO105B02	AT LEAST 6
RESISTANCE TO CHEMICALS DIN423/DIN51958	EXCELLENT
IMPACT SOUND ABSORPTION VLI, ISO 104, ISO717	APROX 2DB



(1) — Certifications & Standards: ISO 9001 ; ISO 14001 ; CE ; CISCA ; VOC ; TUV

SY-G reserves the right to change or modify product design, construction, specifications, or materials without prior notice and without incurring any obligation to make such changes and modifications on SY-G products previously or subsequently sold.



CABINET SOLUTIONS

Cabinets optimize space in data centers and host electronic, communications, and telecommunications equipment. These metallic structures provide safety, organization, and ease of access to these critical devices.

SY-G[®]

Empowering New Frontiers™



INDEX

CATEGORY

CABINET SOLUTIONS



Our cabinet solutions portfolio includes two different series: Server Applications and Telecommunications Applications

SERVER APPLICATIONS SR SERIES

TELECOM APPLICATIONS TM SERIES

NOMENCLATURE

Series	Width (mm)	Depth (mm)	Height (U)	Internal Code
SR: Server Applications TM: Telecommunications Applications	6: 600 mm 8: 800 mm	10: 1000 mm 11: 1100 mm 12: 1200 mm	42	Internal Kardex Code
SR	6	10	42	KS





SERVER APPLICATIONS

SR SERIES

600 mm width

FEATURES:

- Maximum static load capacity : 1300 kg
- Ventilation rate: 75%
- Convex-type, high-density mesh doors
- Integrated assembly structure design with an adjustable equipment installation U-column in the front and rear
- Equipped with casters and support feet
- Multiple closeable wiring openings in the upper and lower parts of the cabinet
- Efficient and solid cabinet parallel connection
- Front and rear doors with advanced spin locks
- Side doors with spring-buckling lock for easy installation without tools
- SPCC good quality, cold-rolled

BENEFITS:

- Doors perforation enhances ventilation and external observation of the technological equipment
- Fine and sober appearance, precision-sized and crafted matching the user's computer room perfectly
- U-column for an easy installation of other power distribution modules
- Meets ANSI /AIARS-310-D, DIN41491, PARTE, IEC60297-2, DIN41494, PART7 and GB/T3047.2-92 standards, compatible with 19" international standards, metric standards and ETSL standards





TELECOM APPLICATIONS

TM SERIES

800 mm width

FEATURES:

- Maximum static load capacity: 1300 kg
- Ventilation rate: 75%
- Convex-type, high-density mesh gate
- Integrated assembly structure design with an adjustable equipment installation U-column in the front and rear
- Can be equipped with casters and support feet
- Multiple closeable wiring openings in the upper and lower parts of the cabinet
- Efficient and solid cabinet parallel connection
- Front and rear doors with advanced spin locks
- Side doors with spring-buckling lock for easy installation without tools.
- SPCC good quality, cold-rolled

BENEFITS:

- Doors perforation enhances ventilation and external observation of the technological equipment
- Fine and sober appearance, precision-sized and crafted matching the user's computer room perfectly
- U-column for an easy installation of other power distribution modules
- Comfortable side spaces for adequate cable management
- Meets ANSI /AIARS-310-D, DIN41491,PARTE, IEC60297-2, DIN41494, PART7 and GB/T3047.2-92 standards, compatible with 19" international standards, metric standards, and ETSI standards

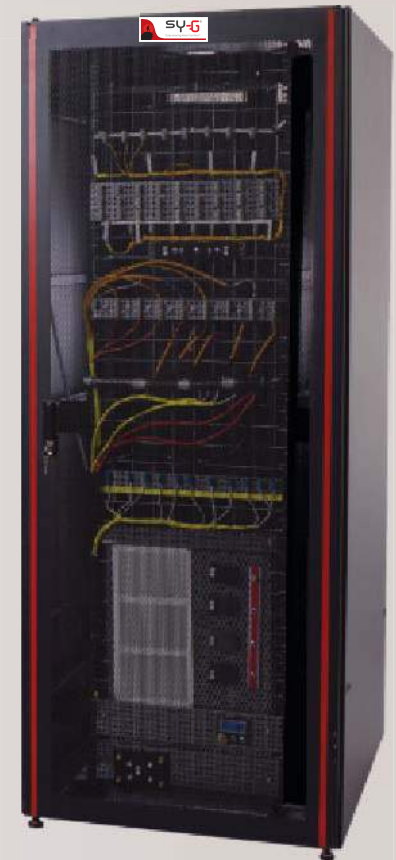



TECHNICAL SPECIFICATIONS: SERVER APPLICATIONS SR SERIES

MODEL	SR61042KS	SR61142KS	SR61242KS
Size: W x D x H (mm)	600 x 1000 x 2000	600 x 1100 x 2000	600 x 1200 x 2000
Usable Height	42U		
Rackmount Width (EIA-310-E)	19"		
Load rating (KG)	1300		
Ventilation	75%		
Cable Management	Accessories available		
Quality Certifications	ISO 9001 ; ISO 14001 ; OHSAS 18001		
Standard Compliance	CE: IEC 60950-1 & IEC60297-2; IECQ CQ080000 ; ANSI /AIARS-310-D ; DIN41491-PARTE ; DIN41494-PART7 ; GB/T3047.2-92		

SY-G reserves the right to change or modify product design, construction, specifications, or materials without prior notice and without incurring any obligation to make such changes and modifications on SY-G products previously or subsequently sold.



TECHNICAL SPECIFICATIONS TELECOM APPLICATIONS TM SERIES

MODEL	TM81042KS	TM81142KS
Size: W x D x H (mm)	800 x 1000 x 2000	800 x 1100 x 2000
Usable Height	42U	
Rackmount Width (EIA-310-E)	19"	
Load rating (KG)	1300	
Ventilation	75%	
Cable Management	Accessories available	
Quality Certifications	ISO 9001 ; ISO 14001 ; OHSAS 18001	
Standard Compliance	CE: IEC 60950-1 & IEC60297-2; IECQ CQ080000 ; ANSI /AIARS-310-D ; DIN41491-PARTE ; DIN41494-PART7 ; GB/T3047.2-92	

SY-G reserves the right to change or modify product design, construction, specifications, or materials without prior notice and without incurring any obligation to make such changes and modifications on SY-G products previously or subsequently sold.



CABINETS

ACCESSORIES

HORIZONTAL CABLE ORGANIZER

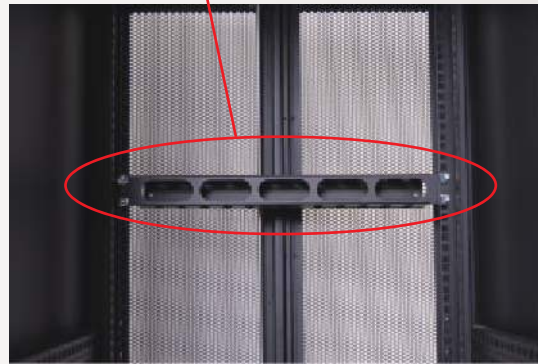

BLANKING PANELS



VERTICAL CABLE ORGANIZER

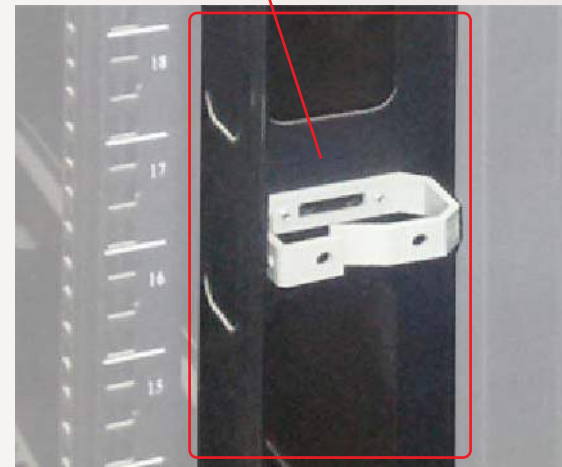

LAYER BOARD

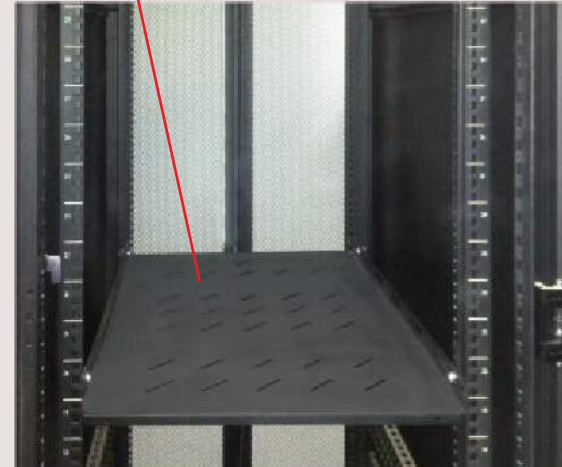

INTEGRATED SOLUTIONS

Compact Datacenter an all-in-one solution created specifically to power, cool, and protect valuable electronic and telecommunication assets. Our integrated solutions guarantee reliability, availability, and continuity for any business, no matter its size.



INTEGRATED SOLUTIONS

SY-G[®]

Empowering New Frontiers™



INDEX

CATEGORY



COMPACT DATACENTER

CDC SERIES

FEATURES:

- *Designed for a maximum load of 6 KVA*
- *Cabinet constructed with cold-rolled steel sheet and coated with high-strength electrostatic paint, includes front and rear hermetic doors made of galvanized steel*
- *Cabinet Includes: double safety locks, access control per door, studs to allow perfect adjustment of equipment, grommets, and lateral cable access*
- *Rack-mounted UPS for electrical protection with modular growth capacity*
- *Rack-mounted PDU for an organized electric distribution*
- *Side-mounted 3 KW cooling system (PC Series), engineered for continuous operation, controlling the temperature inside the cabinet through sensors.*
- *Emergency fans powered by the UPS to back-up the cooling system in case of over temperature or power failure*
- *Fire detection and suppression system includes: Control panel, two photoelectric detectors, manual release and abort switches, stroboscopic lights, suppression cylinder containing environmentally friendly clean agent, piping and discharge nozzles.*
- *Integral monitoring system for all elements of the Compact Datacenter, which sends notifications via SMS and e-mail for a remote administration*
- *IP security system including one camera per door for physical control*

BENEFITS:

- *Ideal for small applications or remote sites*
- *Designed to protect sensitive equipment from external agents*
- *Ease of access to cabinet interior for equipment installation and maintenance*
- *External side mounted air conditioner to optimize internal space and ease of maintenance*
- *Remote administration via SMS and e-mail*
- *Provides communication redundancy through SNMP card via LAN/WAN and cellular modem*
- *Compliant with EIA-310D, IP-62, and NEMA standards*



CDC) SERIES COMPACT DATACENTER

- 1) UPS (VRN Series)
- 2) PDU
- 3) Side-mount cooling system (PC Series)
- 4) 4 Back-up fans
- 5) Monitoring system
- 6) 2 access control, one per door
- 7) IP surveillance system, 2 dome camera
- 8) Fire detection and suppression
 - a. Control panel
 - b. Cylinder with clean agent
 - c. Photoelectric smoke
 - d. Manual release and abort switches
 - e. Stroboscopic lights
- 9) Wheels for easy movement
- 10) Ground bus
- 11) 2 hermetic doors (front and rear)



TECHNICAL SPECIFICATIONS
(CDC) SERIES
COMPACT DATACENTER



MODEL	CDSYG3LFC	CDSYG5LFC
UPS	Computer Power Model: VRN-3KVA	Computer Power Model: VRN-6KVA
Phase	Single-Phase	Two-Phase
Capacity	3000 VA / 2700 W	6000 VA / 5400 W
Input Nominal Voltage	80 - 150 VAC	80 - 140 VAC (L-N) 138 - 242 (120° - 240°) 160-280 (180°) (L-L)
Input Power Factor	At Full Load > 0.99	
Input Frequency Range	40-70 Hz	
Output Voltage Range	110/115/120/127 VAC ± 1 %	110/115/120/127 VAC (L-N) 200/208/220/230/240 VAC (L-L) ± 1%
Waveform	Pure Sinewave	
Efficiency (AC Mode)	91%	91%
Batteries	6 x 12V / 10Ah	20 x 12V / 9Ah
Dimensions (WxDxH) (mm)	438 x 630 x 88 [2U]	UPS: 438 x 668 x 133 [3U] ; Battery: 438 x 580 x 133 [3U]
PRECISION AIR CONDITIONER	Sy-G Model: PCLA3SL1PAT	Sy-G Model: PCLA5SL1PAT
Supply air scheme	L: Lower front discharge	L: Lower front discharge
Total capacity KW [Btu/h]	3.06 [10,441]	5.0 [17,060]
RefrigerantType	R134A	R134A
Power source	208 V, 1 Ph, 60Hz	208 V, 1 Ph, 60Hz
Protection	IP55	IP55
Working Temperature range	-5~50 °C	-10~50 °C
Dimensions (W x D x H) (mm)	549 x 220 x 1,208	549 x 251 x 1,336
FIRE DETECTION & SUPPRESSION SYSTEM		
Control Panel	SHP-PRO	
Sensors	2 Photo-electric	
Nozzle	1 ; 180 degree	
Suppression Type	Clean Agent HFC-125	
MONITORING SYSTEM		
Type of unit	Rack-mount 19"	
Controlled Devices	UPS Systemes, gate operation, environment control, operating devices via dry contacts, IT devices	
Network Protocols	TCP/IP, UDP/IP, HTTP, MODBUS, SNMPv2, SMTP, TELNET, SMS	
Ethernet & Connectivity	10/100 Base, RJ45 - LAN / WAN, GSM (Optional)	
Alarm notification	Email & SMS	
SECURITY SYSTEM		
Device Type	2 Fixed Indoor Dome Camera	
Functionality	Day and Night with IR LED	
Ethernet Port	1, Ethernet (10/100 Base-T), RJ-45 connector	
Security	IP address filtering; HTTPs encryption; Password protected user levels; Anonymous login; network access control	
GENERAL CABINET		
Dimensions (WxDxH) (mm)	Fully assembled: 1,030 x 1,080 x 2,220; Main Cabinet: 82 x 1,080 x 2,220	
Load Capacity	Gross load capacity: 1300 Kg ; Free load capacity: 900 Kg	
Structure	Cold-rolled steel sheet coated with high-strength electrostatic paint	
Hermetic Doors	2 (Front & Rear)	
Emergency fans	4 fans powered by the UPS	
ACCESS CONTROL		
General	2 one per door	
Keyboard	Numeric, four-digit code	
STANDARDS		
Self-compliance	EIA-310D, IP-62, NEMA	

SY-G reserves the right to change or modify product design, construction, specifications, or materials without prior notice and without incurring any obligation to make such changes and modifications on SY-G products previously or subsequently sold.

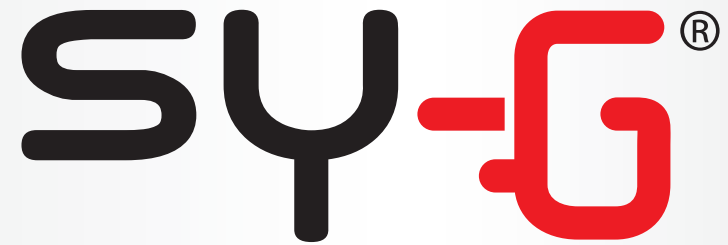

Empowering New Frontiers™

